

INFANTRY LIVE-FIRE TRAINING

CONTENTS

	Page
Preface	iv
CHAPTER 1. TRAINING STRATEGY	
1-1. Army Philosophy of Live-Fire Exercises	1-1
1-2. Concept	1-2
1-3. Terms	1-2
1-4. Strategy Development	1-3
1-5. Cycle Sustainment Training Strategy	1-5
1-6. Training Building Blocks	1-7
CHAPTER 2. WEAPON PROFICIENCY TRAINING	
2-1. Background	2-1
2-2. Live-Fire Exercise Training Concepts	2-5
2-3. Engagement Variables	2-5
2-4. Soldier Skill Variables	2-7
2-5. Unit Skill Variables	2-8
2-6. Conduct of the Live-Fire Exercise	2-10
CHAPTER 3. BUDDY-TEAM TRAINING	
3-1. Introduction	3-1
3-2. Objectives	3-1
3-3. Buddy-Team Collective Tasks	3-2
3-4. Example Buddy-Team Defense (Exercise 1)	3-3
3-5. Example Buddy-Team Offense (Exercise 2)	3-5
3-6. Logistic Support	3-6
CHAPTER 4. FIRE-TEAM TRAINING	
4-1. Introduction	4-1
4-2. Objectives	4-2
4-3. Focus	4-2
4-4. Training Sequence	4-4

	Page
4-5. Example Rattle-Battle Drill (Known-Distance Range) ..	4-4
4-6. Logistic Support	4-6
 CHAPTER 5. SQUAD TRAINING	
5-1. Introduction	5-1
5-2. Objectives	5-1
5-3. Focus	5-2
5-4. Planning	5-3
5-5. Setup	5-6
5-6. Execution of the Live-Fire Exercise	5-7
5-7. Observer-Controllers	5-8
5-8. Assessment	5-8
5-9. After-Action Reviews	5-9
5-10. Squad Mission	5-9
5-11. Logistic Support	5-11
 CHAPTER 6. PLATOON TRAINING	
6-1. Introduction	6-1
6-2. Objectives	6-1
6-3. Focus	6-2
6-4. Planning	6-3
6-5. Setup	6-5
6-6. Execution of the Live-Fire Exercise	6-5
6-7. Observer-Controllers	6-6
6-8. Assessment	6-6
6-9. After-Action Review	6-6
6-10. Platoon Mission	6-6
6-11. Logistic Support	6-8
 APPENDIX A. SAFETY	 A-1
APPENDIX B. SITE SELECTION AND PREPARATION	B-1
APPENDIX C. LIVE-FIRE TRAINING ENHANCERS	C-1
APPENDIX D. SPECIAL CONSIDERATIONS FOR NIGHT EXERCISES	D-1
APPENDIX E. LIVE-FIRE LESSONS LEARNED (JRTC)	E-1
APPENDIX F. MISSION-BASED AMMUNITION REQUIREMENTS	F-1

	Page
APPENDIX G. SURFACE DANGER ZONES AND SAFETY FANS	G-1
APPENDIX H. OBSERVER-CONTROLLER INFORMATION	H-1
APPENDIX I. FIRE CONTROL	I-1
APPENDIX J. LIVE-FIRE ASSESSMENT	J-1
APPENDIX K. TRAINING AREAS AND RANGES	K-1
GLOSSARY	Glossary-1
REFERENCES	References-1
INDEX	Index-1

PREFACE

This publication bridges the gap between individual and collective marksmanship training. It addresses both fire and maneuver with emphasis on LFXs for dismounted infantry. This publication is for use by all leaders of infantry units and should be used in conjunction with ARTEP 7-8-MTP and ARTEP 7-7J-MTP. It provides guidance and examples to help the commander set up his own LFXs based on his unit's METL. It complements existing training manuals and assists commanders in planning, executing, and evaluating LFXs. Some duplication occurs among chapters. The intent is to allow junior leaders executing training to read and copy only those chapters pertaining to them.

This publication focuses on training the trainer to conduct measurable and realistic LFXs at buddy-team through platoon level. It also provides the company, battalion, and brigade with a document that outlines the resources available and their costs. It is not a sole-source document. (See the references for a list of manuals to study before conducting an LFX.) Leaders should always check Army and installation safety regulations, and doctrine and training manuals before conducting an LFX.

The proponent of this publication is the US Army Infantry School. Send comments and recommendations on DA Form 2028 directly to Commandant, US Army Infantry School, ATTN: ATSH-OTT-T, Fort Benning, GA 31905-5594.

Unless this publication states otherwise, masculine nouns and pronouns do not refer exclusively to men.

CHAPTER 1

TRAINING STRATEGY

To be successful on the battlefield, the commander must know the capabilities of his weapons and soldiers. He should use LFXs to train under warlike conditions. This chapter discusses the Army's philosophy of LFXs; the live-fire training concept; how to develop a training strategy; special terms used to discuss LFXs; and the cyclic, progressive sustainment strategy needed to maintain a unit's live-fire skills. For a commander's training strategy to be productive, he must train the trainer. A review of this circular, classes and discussions, and a TEWT provide a good start in training the trainer on the basics of live fire. If unit leaders are not trained first, resources are wasted and soldier death and injury occur.

1-1. ARMY PHILOSOPHY OF LIVE-FIRE EXERCISES

The Army's philosophy of LFXs is to train to combat readiness, which includes—

- Establishing a commander's maneuver area or box where the leader can select the direction and method of fire and maneuver based on METT-T.
- Integrating all organic and nonorganic (direct and indirect) weapons systems and personnel.
- Exercising all combat-related activities (for example, casualty collection and evacuation and combat service support) to include platoon slice elements to support squad training and company slice elements to support platoon training.
- Using realistic targetry and return fire (MILES and simulators).

Everyone is responsible for safety during the LFX. Range control supports the commander in the conduct of realistic live-fire exercises unhampered by artificial safety restrictions. Their primary concern is that no rounds exit the maneuver area, not the methods of fire integration and maneuver within the box. Also, LFXs should combine Army training doctrine and literature (Figure 1-1, page 1-2).

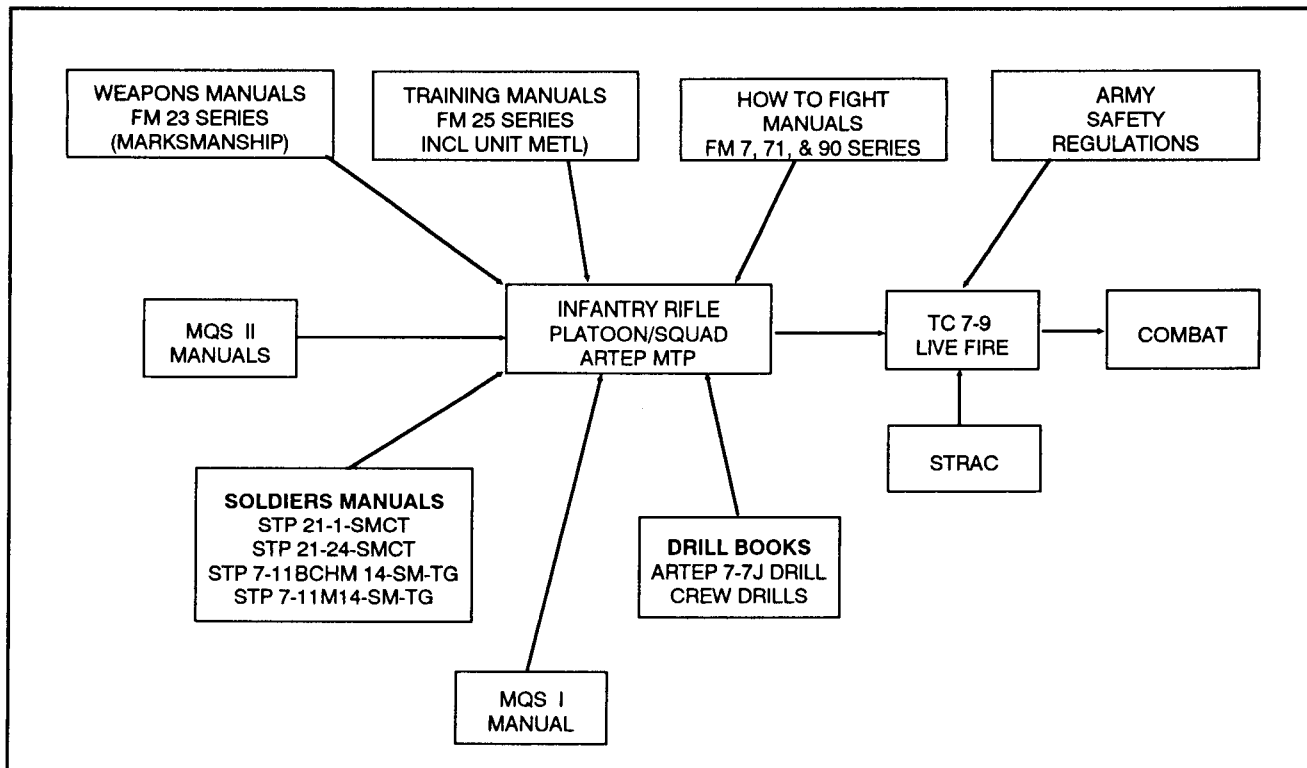

Figure 1-1. Supporting Army training doctrine and literature.

1-2. CONCEPT

Live-fire training must be coupled with force-on-force training. Each complements the other with different aspects of combat realism. Conducting force-on-force training with MILES reinforces realistic actions during LFXs. Live-fire training trains the unit in many areas. One of the most important is marksmanship. Marksmanship encompasses the employment and accuracy of all weapons and weapon systems; this includes grenade marksmanship, machine gun marksmanship, antiarmor marksmanship, and so forth.

1-3. TERMS

The following terms are used when discussing LFXs.

a. **Static Firing Range.** This range involves no movement once firing begins. It is typically used for missions such as defend or conduct an ambush (unless assault fire is used during the ambush). An example of a static range is the individual qualification range.

b. **Maneuver Range.** This range involves fire and movement and may be used for missions such as attack or movement to contact. An example of a maneuver range is the multipurpose range complex (MPRC).

c. **Collective Marksmanship.** Collective marksmanship refers to the accuracy of multiple weapon systems by a group of two or more soldiers.

d. **Maneuver Box.** A maneuver box is a temporary or permanent designated training area that allows units to approach an objective using organic and nonorganic weapons systems in a live-fire scenario. This box might use parts of the installation impact area for maneuver and or fire. (See Appendix G for more information.)

e. **Static Marksmanship.** Static marksmanship involves no movement after firing begins.

f. **Mobile Marksmanship.** Mobile marksmanship involves firing while moving.

1-4. STRATEGY DEVELOPMENT

Infantry units have different amounts and types of equipment and personnel. All of these components must be included in a training strategy.

a. Figures 1-2 through 1-5 show the components of the systems addressed in this manual. These systems can be supplemented to match any unit's organization.

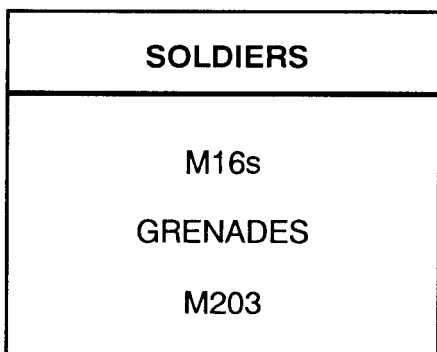

Figure 1-2. Buddy-team system.

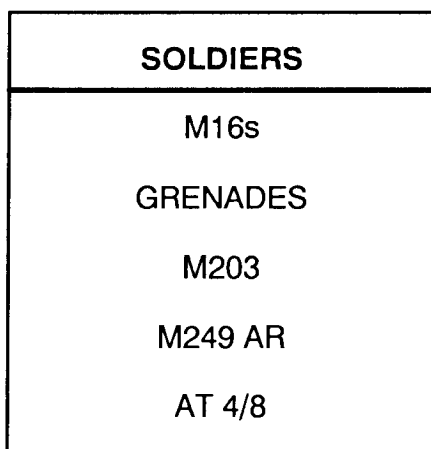

Figure 1-3. Fire-team system.

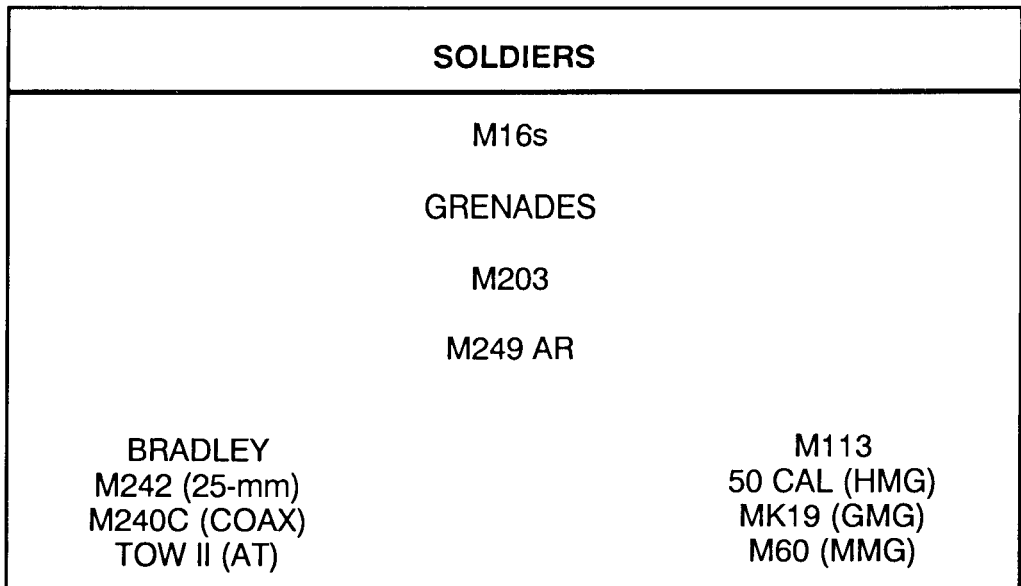

Figure 1-4. Squad system.

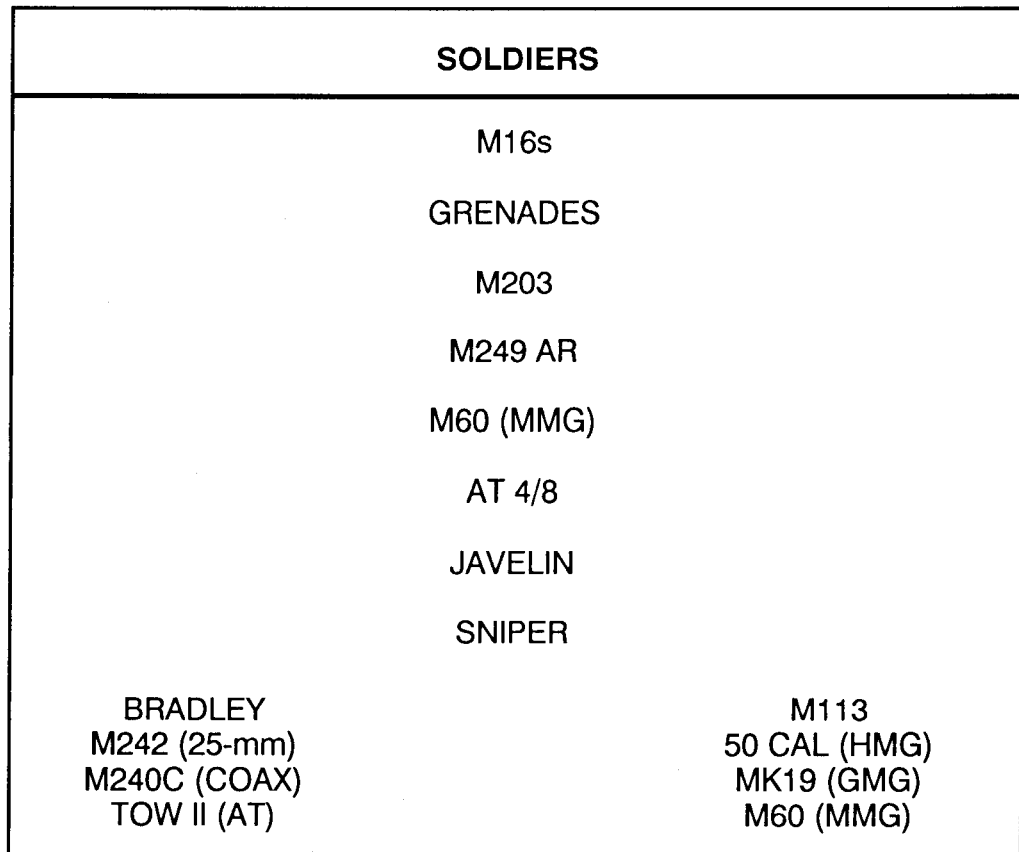

Figure 1-5. Platoon system.

b. At times the components of a system may vary—personnel strengths rarely remain constant; specific weapons may be turned in for maintenance. The key is for the unit commander to train and plan for assigned systems and possible contingencies.

1-5. CYCLE SUSTAINMENT TRAINING STRATEGY

Every unit undergoes personnel turnover. In order to attain combat proficiency and sustain it, units should plan progressive, sequential training to develop their weapon crews, buddy teams, fire teams, squads, and platoons. This sequential training is done in seven stages beginning with individual training.

a. Individual training begins in initial-entry training (IET). This training must be expanded and sustained in the unit. Stage 1 includes individual sustainment training in the unit, which might cover weapons maintenance and zero, static marksmanship (current qualification), and mobile marksmanship (a concept where the soldier goes beyond current qualification practices and learns to fire and move at the same time—for example, quick fire and assault fire while moving forward in the offense, or while breaking contact).

b. Collective marksmanship training consists of six stages: Stage 2, Crew; Stage 3, Buddy Team; Stage 4, Fire Team; Stage 5, Squad; Stage 6, Platoon; and Stage 7, Company and larger units. These stages might cover these areas:

- Weapons maintenance and zero/calibration (for crews).
- Static marksmanship (defense, ambush).
- Mobile marksmanship (attack, withdraw).
- Command and control (movement and direction, rate, and distribution of fires).
- Integrated fires.
- Supporting fires (artillery, mortars, and so forth).
- Range determination and target identification.

c. Unit live-fire training follows a progressive, sequential cycle. These cycles are similar for each stage. The unit can tailor training to its METL.

(1) **Stage 1, Individual.** The cycles in Stage 1 include:

- Zero weapon.
- Qualify with assigned weapon (rifle, pistol).
- Familiarize with hand grenade and M203.
- Perform advanced individual techniques (dry fire of combat record fire): engage enemy with multiple systems (rifle, bayonet, grenade); conduct mobile marksmanship (assault fire, quick fire, and so on); and focus on individual movement techniques (IMT).
- Rehearse (blanks/MILES).

- (2) **Stage 2, Crew.** The cycles in Stage 2 include:
- Qualify with assigned crew-served weapon.
 - Dry fire (engage enemy with multiple systems).
 - Rehearse (blanks/MILES).

- (3) **Stage 3, Buddy Team.** The cycles in Stage 3 include:
- Dry fire (engage enemy with multiple systems).
 - Rehearse (blanks/MILES).
 - Conduct LFX (fire and movement).

NOTE: This is the first coordinated movement exercise (fire and movement). IMT and communication (to include arm-and-hand signals) should be refined during this exercise.

- (4) **Stage 4, Fire Team.** The cycles in Stage 4 include:
- Dry fire (engage enemy with multiple systems).
 - Rehearse (blanks/MILES).
 - Conduct LFX (optional, based on ammunition availability; can be integrated with squad).

NOTE: This is the first step that requires command and control.

- (5) **Stage 5, Squad.** The cycles in Stage 5 include:
- Dry fire (engage enemy with multiple systems).
 - Rehearse (blanks/MILES).
 - Conduct LFX. This squad exercise could also be combined with the platoon LFX. With the introduction of maneuver, the command and control process (by fire team and squad leaders) complicates the exercise. Force-on-force training must precede all LFXs at this level and higher.

- (6) **Stage 6, Platoon.** The cycles in Stage 6 include:
- Dry fire (engage enemy with multiple systems).
 - Rehearse (blanks/MILES).
 - Conduct LFX (combined with squad). Command and control by fire team, squad, and platoon leaders is more difficult. In addition, supporting fires must be integrated. This includes infantry platoon organic and nonorganic systems like the Bradley fighting vehicle, antiarmor systems, mortars, and artillery. Indirect fires must be integrated at this level.

(7) **Stage 7, Company and Larger Units.** The cycles in Stage 7 are similar to those in Stage 6 with increased emphasis on nonorganic and or combined-arms systems.

d. Sustainment training is always cyclic. In most units, personnel turnover and the natural erosion of individual and collective skills requires a plan for sustainment. The commander must constantly assess the proficiency of his squads and platoons and retrain them in the needed collective tasks.

e. Before any training is conducted that expends blank or live ammunition, a dry-fire or walk-through exercise should be conducted. This allows the unit to improve movement techniques, command and control, safety, and many other areas before critical resources are used. If units use manuals like ARTEP 7-8-DRILL as a guide, and follow the crawl, walk, run concept (Chapter 2), they will get the maximum training effect from their ammunition and will enhance safety.

f. The focus of training must go beyond rifle marksmanship and include hand grenades, machine guns, and antiarmor missiles. Individuals must undergo a sustainment program with all weapon systems they will use in combat. This sustainment program is run by the unit, based on the commander's assessment. (See References for a list of training manuals.)

1-6. TRAINING BUILDING BLOCKS

In order to reach a training goal, units must first learn basic tasks. Each task or group of tasks is a building block used to progress to a higher level of training. Once a foundation is laid, the unit begins to build on it layer by layer, until the final objective is achieved (Figure 1-6).

TRAINING LOCATION	THE PLATOON PREPARED FOR WAR	OBJECTIVE STAGE
UNIT	Platoon Training SQUAD/PLT LFX	6
UNIT	Squad Training ARM : SQUAD/PLT LFX	5
UNIT	Fire Team Training ARM : FIRE AND MOVEMENT	4
UNIT	Crew Training MAINTENANCE : ZERO : QUAL : CREW DRILL	3
IET/ UNIT	Buddy-Team Training FIRE AND MOVEMENT	2
IET/ UNIT	Individual Training WPN MAINTENANCE : BRM : ZERO : QUALIFICATION	1

Figure 1-6. Example of training building blocks.

a. A training building block may consist of several individual tasks. When individuals or units are proficient in all tasks, they are proficient in

the training building block. Training aids can be used to help achieve proficiency in each of the training blocks (Figure 1-7).

INDIVIDUAL	BUDDY TM	FIRE TM	SQUAD	PLATOON
WEAPONER	MILES	MILES	MILES	MILES
MACS	PRACTICE GRENADE	PRACTICE GRENADE	RCMAT	RCMAT
RIDDLE SIGHTING DEVICE			INERT CLAYMORE	INERT CLAYMORE

Figure 1-7. Example of training aids.

b. The unit commander must determine how much time and effort to spend on each building block. Some blocks will require little effort to obtain proficiency, while others will demand extensive time, resources, planning, and personnel.

c. IET lays the foundation for basic qualification and familiarization of individual weapons (M16 rifle, M203 grenade launcher, hand grenades, and so on). It also teaches individuals and buddy teams fire and movement. This short exposure to basic skills establishes the foundation that units must build on to ensure a soldier's confidence in himself, his unit, and his leaders. The unit must reinforce and sustain these highly perishable skills and expand them to prepare the unit for war. LFXs should include the training a unit has completed to be combat ready. (DA Pam 350-38 outlines training and qualification requirements.)

CHAPTER 2

WEAPON PROFICIENCY TRAINING

Live-fire training can be the most realistic and stressful training a unit can undergo in preparing for combat. It is a tactical exercise that combines unit tactics with individual and collective marksmanship training. Since the Army employs its weapons in combat to destroy enemy personnel and equipment all units must be proficient in applying live fire to accomplish their mission-essential task list (METL). Units need to continually train collective marksmanship skills and the integration of multiple weapon systems with tactical collective tasks. Trainers should be aware of the variables that affect live-fire marksmanship (mission, target, environmental conditions, and soldier and unit skills) and the procedures necessary to conduct the LFX.

2-1. BACKGROUND

Past combat experiences have pointed out many collective marksmanship lessons. Also, data from the Army's Combat Training Centers (CTC) have pointed out marksmanship problem areas. A small portion of this information is presented here.

a. In recent years, direct-fire proficiency in units has been declining. Research by the US Army Engineering Laboratory at Aberdeen Proving Ground provides the following data regarding enemy engagements:

- Most engagements are at or less than 300 meters.
- A desert environment allows some opportunities for over 300 meters (but, less than 400 meters).
- Jungle or urban engagements occur at less than 100 meters.
- Target exposure time is 3 to 5 seconds for under 200 meters and 5 to 7 seconds in excess of 200 meters.
- Target detection time averages of 6 seconds make it difficult to engage accurately.

In training, 3- to 5-second rushes and firing from the prone or supported fighting position (static) are practiced. The US Army Human Engineering Laboratory provides the following data about what happens in combat:

- 40 percent of those firing are fully exposed.
- 40 percent of those firing are behind cover.

Most firing is executed from the standing or kneeling position (Figures 2-1 and 2-2).

These figures are not surprising considering that soldiers may find themselves in deep grass or thick vegetation while on the move. Falling into the prone position may make them less of a target; however, to return fire, soldiers may need to kneel or stand to see targets.



Figure 2-1. M16 standing position.

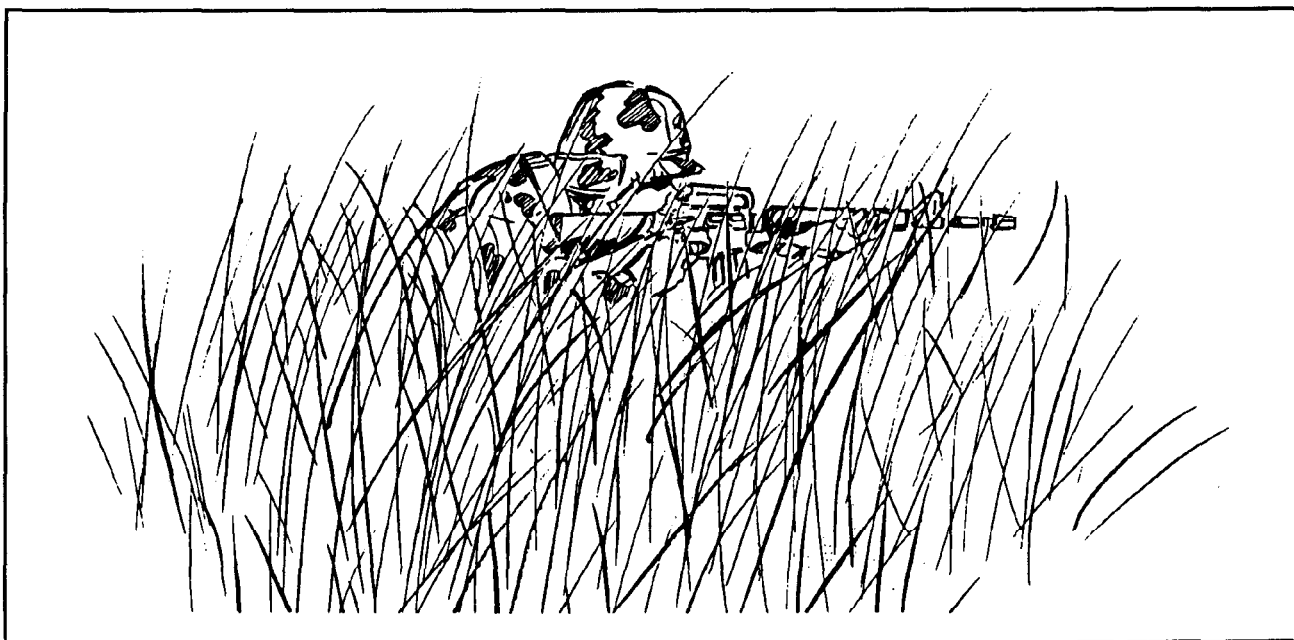

Figure 2-2. M16 kneeling position.

b. Currently, the Army focuses its training and qualification on the M16 rifle with the soldier in the supported fighting and prone positions. While these positions may be good for a planned defense, they could be totally useless in mobile offensive operations, such as a movement to contact or an attack. The soldier has little control over the cover and concealment that exists around and within the enemy's position. He may find himself in tall grass, behind a stone wall, or even in a building. At this point he needs to know, and have experience in firing various weapons from, the standing and kneeling positions and modifications of these positions. (See FM 90-10 for more information on modified firing positions.)

c. The three primary ways of directing fire with a rifle are to: aim through the sights; hold the weapon in an underarm position and use instinct, bullet strike, or tracers to direct the fire (assault fire); or bring the rifle to the shoulder but look over the sights as the rifle is pointed in the direction of the target (quick fire). Most weapon systems have a slightly different manner of fire when employed in an emergency situation, when seconds mean life or death.

d. Units need to evaluate how they train with all weapon systems. Do they only train their soldiers to fire antiarmor weapons like the AT4 and Javelin from the standing position? What difficulties arise if they also trained them to fire from a prone or kneeling position? (Figures 2-3 and 2-4, page 2-4.)

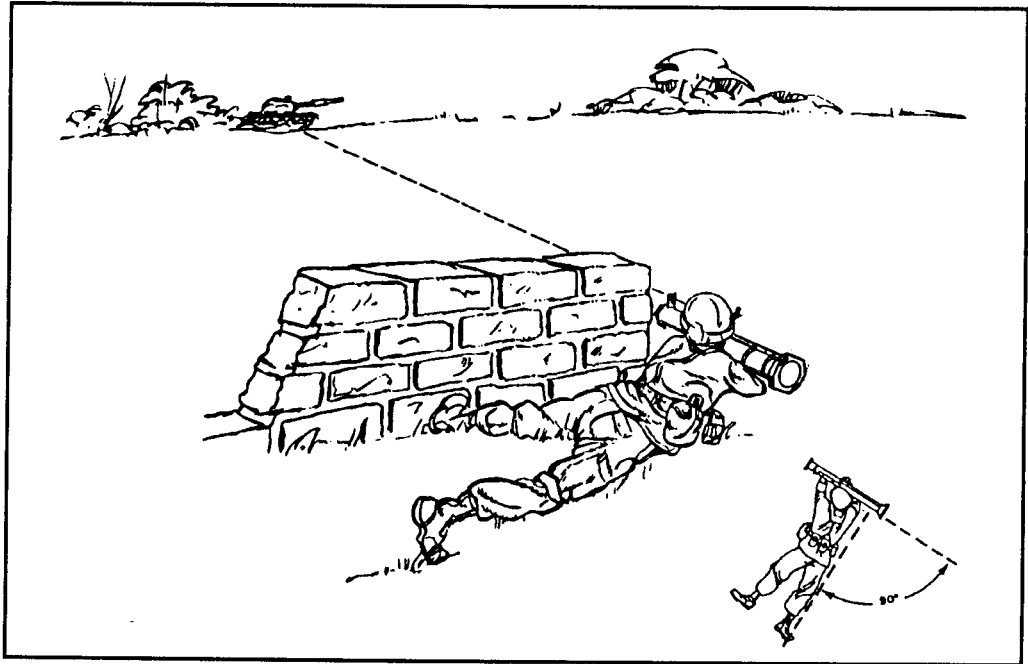

Figure 2-3. AT4 prone position.

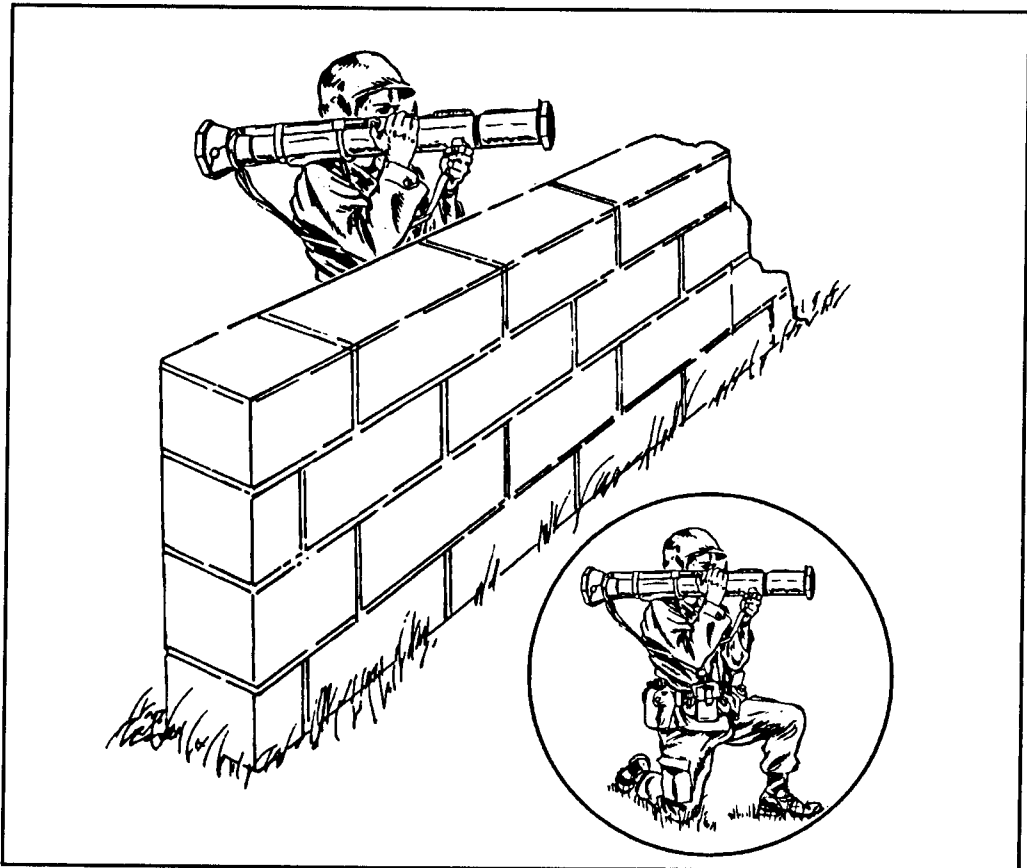

Figure 2-4. AT4 kneeling position.

2-2. LIVE-FIRE EXERCISE TRAINING CONCEPTS

Conducting an LFX is not the same as "going to the rifle range." While many units have made advances in this area, others must strive to train with realism. Before an LFX, the unit leader ensures his personnel are proficient in areas such as individual weapons knowledge and qualification; range determination and target identification; and the basics of fire control measures and movement techniques.

a. **Focus.** Each stage of live-fire training should cover static marksmanship (defense, ambush) and mobile marksmanship (movement to contact, attack, delay).

b. **Objectives.** Live-fire objectives include:

(1) Integrating all weapons systems (organic and attached) to include small arms, hand grenades, antiarmor weapons, mortars, artillery, helicopter gunships, and CAS.

(2) Avoiding a "range mentality." This means not using artificial safety constraints, but using life-like targets; using realistic positioning of enemy (with regard to terrain and OPFOR doctrine) and simulation of the sights, sounds, and smells of battle; and hiding support activities (no nontactical vehicles, ammunition points, and so on).

(3) Integrating nonorganic personnel (FO, snipers, and medic). Many times these people are forgotten in training exercises, but they also need training.

(4) Training fire commands and fire control measures.

(5) Training ammunition conservation.

(6) Providing marksmanship feedback.

c. **Training Sequence.** The crawl, walk, run concept should be used when training for an LFX.

- Crawl-dry fire (walk-through). This may or may not be conducted on the LFX objective depending on METT-T, the commanders training objectives, and his risk analysis. The commander may approve the use of similar terrain instead.
- Walk—MILES (blanks). A force-on-force exercise in this phase of training is important to help prevent soldiers from performing unrealistic actions in the LFX.
- Run—LFX.

2-3. ENGAGEMENT VARIABLES (EXTERNAL)

Many variables affect the collective marksmanship of combat. One group of variables are those that come from the nature of the engagement of the threat (targets). These variables come from the mission to be performed, the type and numbers of targets, and environmental conditions.

a. **Soldier Mission.** Soldiers will find themselves engaging the enemy in one of two types of situations: static (defense, ambush) or moving (attack,

movement to contact, delay). Each situation stresses different soldier and unit skills.

(1) **Static.** The soldier must set up a position where he can engage the threat. Clearing fields of fire, covering dead space, and preparing the supported firing position itself are important.

(2) **Moving.** For missions of this type, the soldier may need to concentrate on firing from the kneeling or standing position. The soldier must be aware that his firing position location will be driven by an uncontrollable tactical situation. He may also have to fire while moving (quick fire and assault fire).

b. **Target.** Targets can take on many forms and have a variety of speeds and directions of movement—all of which determines the method of engagement.

(1) **Quantity (single or multiple).** The target quantity may decide the weapon system used. If the target is a single enemy soldier, an M16 might be preferred. If it is a well-prepared enemy platoon, artillery fire might be more effective. While this decision could rest with the individual (rifle, grenade, or bayonet), this is largely a command and control question for the leader.

(2) **Range.** Target range affects the choice of weapon system used in the engagement and the time fires are initiated. Against a tank, a soldier might use a Javelin at 300 meters and a TOW at 2,000 meters.

(3) **Movement (direction, speed, angle).** Practice and experience are needed to know how and when to adjust fire for moving targets, depending on the angle to the target (frontal, flanking, oblique, enfilade).

(4) **Type (area/point, personnel/equipment).** The type of target drives whether a unit uses a rifle or a machine gun, an M203, or a mortar barrage.

c. **Conditions.** Battlefield conditions affect how the threat is engaged. Integrating these variables into training is important.

(1) **Day.** This is the condition trained for most and may be the one experienced least.

(2) **Night (limited visibility, smoke, fog).** Using a night vision device (NVD) increases the number of tasks required to engage a target. For instance, each time an NVD is attached to or detached from a weapon, the weapon must be zeroed or time should be taken to verify the zero. In addition, weapons should be laid into position to ensure fire into areas where targets cannot be seen, yet are likely to appear. Targets may not be seen due to limited visibility, limited illumination, or concealment (including dead space).

(3) **Weather (rain, snow, ice, cold, heat).** Equipment should be kept dry. The soldier should not be too warm or too cold. If the firer is too warm, sweat may get into his eyes affecting his marksmanship. If too cold, he may

have problems using his hands. Wearing gloves complicates firing weapons.

(4) **Nuclear, Biological, and Chemical.** An NBC environment places additional difficulties on the marksman. He must engage targets with all weapon systems while wearing the protective mask and equipment.

(5) **Equipment.** The enemy may employ laser weapons. Therefore, soldiers may need special equipment (such as spectacles) to protect their eyes. They may also have to use items such as body armor and thermal sights. Also, proper reaction to weapon malfunctions must be trained.

(6) **Safety.** Force protection is needed in combat although it places some restrictions on target engagements. Situational awareness is key. However, separating range safety from combat safety (and eliminating artificial range safety when possible) is important.

(7) **Obstacles.** Obstacles may require modification of learned individual firing techniques. The MOUT environment, for instance, may require instances of opposite shoulder firing (See FM 90-10-1.) Obstacles also complicate collective marksmanship and collective tasks. Friendly obstacles must be integrated into the unit fire plan to be effective. Enemy obstacles must be integrated into the battle plan. They will have to be breached or bypassed. (Remember, the enemy will cover his obstacles by fire also.)

2-4. SOLDIER SKILL VARIABLES (INTERNAL)

Other variables that affect collective marksmanship are in individual soldier skills. These variables include the soldier's ability to detect and acquire the target and execute the engagement (based on marksmanship fundamentals). The soldier's skills in suppression and fire discipline also affect the unit's marksmanship.

a. **Detection.** Target detection involves finding the enemy using indicators such as sound, movement, and identifiable shapes. Enemy personnel are seldom visible except when assaulting. Most combat targets can be detected by smoke, flash, dust, noise, or movement. This variable will be affected by the illumination level and the distance, size, shape, texture, and color of the target. Training (in techniques such as scanning) and equipment (optical sights) assist the soldier in detection.

b. **Acquisition.** Target acquisition involves mentally marking the target and determining the range.

c. **Identification.** Soldiers must be trained to identify the target. The lack of this ability is the leading cause of fratricide.

d. **Engagement.** Target engagement involves four fundamentals (rifle): steady position, aim, breathing, and trigger squeeze (FM 23-9). The soldier must apply the fundamentals in all positions (supported fighting, prone, kneeling, standing, modified) and under all conditions (night, NBC

environment). He uses a variety of positions to fire effectively on a target. Many times the available cover and weapon support are the same. For example, a combat firing position may allow the handguard to rest directly on sandbag support while the nonfiring hand holds the weapon at the magazine well.

(1) Not only must the soldier know how to fire his weapon from various positions, but he must also know when, and by what method, he is to use it. For example, most combat fire will be directed at an area where the enemy is suspected, but not seen. Visible targets can be engaged by using nearby objects as reference points.

(2) Suppression is the act of making an enemy target ineffective. Whether the target becomes immobilized, withdraws, or is destroyed is not always important.

(a) Suppression requires sustained, accurate fire. It is *NOT* the act of spraying rounds downrange. The amount of ammunition required to suppress a target varies with the target itself. For example, only one M16 round every minute may keep a sniper pinned down, whereas 10 rounds a minute might be needed on an enemy fighting position or even 60 rounds a minute along a woodline. The rate of fire should be controlled. If suppression for long periods is necessary, ammunition could run out. This would put maneuvering forces at risk, especially if all ammunition was expended to suppress a bunker just as the maneuver element was prepared to take it out through close assault.

(b) The return rate of fire and accuracy of fire from the enemy position, along with the amount of friendly casualties, indicate if suppressive fires are effective. Destroying the target is not always possible. For example, when suppressing a bunker, fire should be aimed at its firing ports. Sending rounds through the firing ports may keep the enemy laying on the bunker floor, making that position ineffective.

(c) One problem with suppression is that when firing stops, the target may become active again. Suppressive fire should be used for a specific reason (to bypass a target or maneuver forces against it) to make expenditure of ammunition worthwhile.

e. **Fire Discipline.** Fire must be precisely aimed, controlled, and conserved to avoid wasting ammunition. Soldiers must follow the commands of their fire-team leader and squad leader.

2-5. UNIT SKILL VARIABLES

A unit's leadership also affects collective marksmanship. Command and control might affect when, and with what weapons, a target is engaged. The leader's placement of his soldiers may affect their ability to see and engage the target. The leader must consider fire control and fire control measures that affect marksmanship. Additionally, a leader's actions in

preserving the force will influence how the soldiers shoot (for example, has the soldier gotten enough rest).

When units go into battle, control is the most difficult but important factor influencing the outcome. In large units, directives and orders can be issued with limited interference during all phases of battle. However, in the squad, platoon, and company, enemy action influences and often prevents or restricts orders and signals.

a. **Command and Control.** Command and control is the exercise of authority and direction over assigned forces in the accomplishment of a mission. This process must distinguish, from the flood of information, those items that will allow the leader to make timely decisions. Command is the process of the leader converting that information into direction. Control is the execution of that direction. *Communication and training* is the bridge between command and control.

(1) Communication by the leader is usually by written and oral commands (messenger, radio, and wire) or sound and visual signals (whistles, bells, arm-and-hand signals, pyrotechnics, flags, lights, and mirrors).

(2) In the heat of battle, attempts at all forms of communication can be futile. Intensive training in the areas of SOPs and battle drills can reduce the need for communications.

b. **Fire Control.** Improper fire control could result in the loss of surprise, fratricide, engaging unimportant targets, or loss of superior firepower, and initiative. Fire control (through the use of fire commands and control measures) requires the ability to select and designate targets, open fire at the desired time, adjust fire, regulate the rate of fire, shift from one target to another, and cease fire.

(1) Fire control measures include sectors of fire, target engagement priorities, engagement areas (EAs), target reference points (TRPs), phase lines (PLs), boundaries, restrictive fire areas (RFAs), and restrictive fire lines (RFLs). Fire control measures should be simple, easy to see, and keyed to terrain features such as a house, tower, hilltop, enemy bunker, river, road, or woodline. During any training exercise, these measures should be evaluated. Fire control measures are an integral part of LFXs—determining if targets are destroyed and suppressed with the minimum expenditure of ammunition and time. (Appendix I provides a detailed account of using various fire control measures.)

(2) Fire commands can be executed by the desired control measures. They take the form of oral commands, arm-and-hand signals, prearranged signals, personal contact, and SOPs. (Specific fire commands for various weapon systems can be found in the appropriate field manual.) Figure 2-5 (page 2-10) shows an example of some fire commands.

ALERT	Fire mission.
DIRECTION	Front.
DESCRIPTION	Troops in the open.
RANGE	800 meters
METHOD OF FIRE	Fixed, traverse, search, traverse, and search
COMMAND TO FIRE	At my command, FIRE

Figure 2-5. Example fire commands.

c. **Preserving the Force.** Unit leaders need to keep in mind the sleep plan, speed of movement, and when to execute various maneuvers to preserve the strength and mental clarity of the soldiers. SWA AARs discuss the problem of initiating individual movement techniques and other actions that left, soldiers exhausted before reaching objectives. This is an age-old problem, and leaders need to think about this before and during an LFX, as well as after the exercise to evaluate their decisions.

2-6. CONDUCT OF THE LIVE-FIRE EXERCISE

Many things must be considered in the execution of an LFX. This paragraph highlights some of them.

a. **Safety.** Proper safety measures are critical when conducting an LFX. However, excessive safety measures destroy realistic training and should be avoided. Soldiers must understand that the safety measures practiced in peace are the safety measures practiced in war. If artificial safety restrictions are imposed, the soldiers must understand what the restrictions are and why they are necessary.

b. **Sequence of Events.** Training should be conducted as if the unit were going to war. For example, commanders will conduct some form of an after-action review (AAR) after the battle. Movement, ammunition distribution, sleep/rest plans, and feeding plans should all be conducted tactically. The following is a simplified sequence of events:

- Planning (to include transportation, ammunition, training/operations plan).
- Preparation (to include setup, briefings, orders).
- Leader TEWT (fire team leader and up). TEWT may or may not be conducted on the LFX objective depending on METT-T, the commander's training objectives, and his risk analysis. The commander may approve the use of similar terrain instead.
- Walk-through. This is a dry run concentrating on maneuver, communications, command and control, and safety.
- After-action review (IAW ARTEP standards).

- Rehearsal with MILES. This could be integrated into a tactical exercise as a unit rehearsal before conducting the mission.
- After-action review (IAW ARTEP standards).
- Live-fire exercise.
- AAR to include marksmanship assessment.

c. **Mission and Range Selection.** The commander decides what mission to train and what type of range to use based on his METL and METT-T. However, the following guidelines can be used to select the mission and range.

(1) **Missions.** Usually, training missions and tasks are selected from the appropriate ARTEP MTPs. Exceptions may be required to train individual (and some collective) tasks at the buddy-team and fire-team level. Examples of missions and tasks taken from current MTPs or soldier's manuals are provided in the following chapters for each level of training. As training becomes more sophisticated at the squad and higher levels, commanders are encouraged to sequence different missions and tasks together into a situational training exercise (STX). (See appropriate ARTEP MTPs for further guidance on STXs.)

(2) **Ranges.** Range availability is sometimes the determining factor in range selection. Lane-type ranges should be used for buddy-team and fire-team level exercises. A free-form maneuver box is best at the squad and higher level. This manual provides examples of ranges that could be used for conducting realistic LFXs from the buddy-team to the platoon level. (TC 25-8 provides a listing of the various Army ranges from the buddy team fire and movement range to the company/team MPRC.)

d. **Range Focus.** When setting up a range for an LFX, the unit should strive for realistic conditions. The following should be considered:

(1) Targets should be placed in the same areas an enemy would occupy—not in the middle of an open field. OPFOR doctrine should be used. (This may require portable targetry to allow frequent target reconfiguration.)

(2) For rehearsals, the OPFOR should be tailored to the size unit that is being trained (squads attack OPs, platoons attack squads, and so on). During force-on-force training, the OPFOR should have counter tasks assigned IAW the ARTEP MTP.

(3) Targets should not be exposed for more than 3 to 5 seconds. Targets that are hit should be killed (they should not pop up again). If effective suppression is delivered, targets not hit should be lowered and brought up again only if suppression stops. Soldiers must know that suppression is effective, and they must get used to shifting firing positions to acquire new targets.

(4) Downrange feedback is necessary for an LFX to reinforce marksmanship.

(5) Artificial safety requirements should be avoided. They reduce realism and defeat the reason for the LFX.

(6) Individual training and rehearsals are conducted to allow a safe, productive LFX.

e. **Assessment.** LFX standards should be IAW the appropriate ARTEP MTPs and soldier's manuals. Some of the standards are difficult to measure in a live-fire context. For example, one of the ARTEP 7-8-MTP standards for the platoon/squad assault (7-3/4-1011) is: The platoon kills, captures, or forces the withdrawal of 100 percent of the enemy. To determine whether this standard has been met, the commander must develop criteria that can be measured within the constraints of an LFX. For example, to measure this standard, the commander could decide that hitting 50 percent of the targets constitutes killing, capturing, or driving away the enemy.

CHAPTER 3

BUDDY-TEAM TRAINING

This chapter provides information for live-fire training at the buddy-team level, culminating in an LFX. The LFX demonstrates to the soldier and his chain of command that he has reached the highest state of readiness possible to begin even more complex collective live-fire training. Buddy-team training should take place at platoon level. Examples of ranges and resources are provided to assist the unit in the planning and preparation of training.

3-1. INTRODUCTION

Collective training begins at the buddy-team level. The buddy team is the initial building block that lays the foundation for live fire by the maneuver element—the squad, platoon, or company.

a. While the ultimate goal is to get the squad or platoon into a live-fire maneuver box to simulate combat realism, soldiers must first have a basic knowledge of individual movement techniques. They must also be comfortable with firing and moving next to one another. To accomplish this, the buddy-team live fire takes place in a controlled environment, as opposed to a maneuver box. This is critical if the leader wants to focus training on a limited number of collective live-fire tasks.

b. A small area is needed to setup lanes (two soldiers for each lane) to conduct both offensive and defensive training. While offensive training will occupy most of the training time, the defense should also be addressed.

3-2. OBJECTIVES

Training objectives vary based on the size of the element to be trained, the unit's experience, and the task to be trained (based on the unit's METL). The following example illustrates this point.

An infantry commander knows that his unit has minimal live-fire experience. He decides that he wants to conduct a platoon LFX in a maneuver box in six months. He first reinforces buddy-team fire and movement on the installation's fire and movement range. (Here his focus is on live-fire safety, individual movement techniques, and marksmanship). Next, he will train his fire teams on reinforcing the concepts of fire control, fire discipline, and fire distribution through the use of fire commands on a

known-distance range. Then the commander will train his squads in fire control measures on an infantry squad battle course, integrating all previous training. When he is satisfied that his personnel are prepared in the basics of live fire, he will conduct a leader's CPX to rehearse command and control. Then he will conduct a squad or platoon LFX in a maneuver box.

a. Training objectives at the buddy-team level in the offense are:

(1) Introduction of basic principles of coordinated movement with other soldiers. However, the focus should be on individual movement techniques (IMT).

(2) Communication (oral, arm-and-hand signals).

(3) Suppressive fire using weapons normally found at this level (rifle, M203, hand grenades, and so on).

(4) Individual movement techniques to include standing, kneeling, and modified marksmanship positions.

(5) Use of terrain.

(6) Target detection.

b. Training objectives at the buddy-team level in the defense are:

(1) Introduction of the basic principles of a coordinated defense (integrated fires, sectors of fire, defensive positions, sector sketches, range cards).

(2) Communication (oral, arm-and-hand signals).

(3) Suppressive fire using weapons normally found at this level (M16 rifles, M203 grenade launchers, hand grenades, and so on).

(4) Use of terrain.

(5) Target detection.

3-3. BUDDY-TEAM COLLECTIVE TASKS

This paragraph focuses on the sustainment and expansion of IMT introduced in IET. Commanders should tailor collective tasks based on the unit's needs (METL). As the commander combines different collective tasks and missions into an LFX, he must keep in mind that ammunition is a primary constraint. (See paragraph 3-6. All ammunition data are based on DA PAM 350-38.) Collective tasks should be performed in the crawl, walk, and run sequence.

a. In the crawl phase, the buddy team is oriented to the terrain. As they walk through the exercise, they are reminded of combat basics through briefings, demonstrations, and AARs.

(1) For the defense, combat basics cover identifying sectors of fire, clearing fields of fire, constructing fighting positions, and preparing range cards.

(2) For the offense, the four buddy-team combat fundamentals (cover, concealment, suppressive fires, and team work) and individual movement

techniques (low crawl, high crawl, rushing, negotiating obstacles) are discussed. The team leader should follow the moving buddy team downrange giving the same fire commands that he would give in an LFX. The result is multiechelon training—the leader exercises command and control, and the soldier reinforces his individual tasks.

b. In the walk phase, the buddy team is challenged to demonstrate their understanding of the concepts. Using MILES allows a force-on-force exercise, which increases realism and helps identify weaknesses.

c. When successful in the walk phase, the buddy team moves to the run phase (live fire). Again, the team uses MILES to increase training realism, with the controller using the control gun to cause a "near miss" when the soldier violates a movement principle, or a "kill" when the soldier commits an unsafe act.

3-4. EXAMPLE BUDDY-TEAM DEFENSE (EXERCISE 1)

Each unit should develop a buddy-team LFX based upon its METL. The following is an example of a buddy-team LFX for the defense.

a. Task, Conditions, and Standards.

TASK: Prepare fighting positions.

CONDITIONS: During daylight hours, on terrain that will allow defensive positions to be prepared, given assigned weapons, 30 rounds of 5.56-mm ball (90 rounds for M249) and or 5 TP 40-mm rounds for each weapon, real or practice grenades, MILES, LBE, helmet, and 20 target silhouettes (presented in a sequence to match OPFOR doctrine). The targets will be presented in groups of 4 at 25 meters, 50 meters, 100 meters, 200 meters, and 300 meters within five minutes.

STANDARDS: Construct fighting positions (SMCT 071-326-5703) to include identifying sectors of fire (use sector stakes) and clearing fields of fire (SMCT 071-326-5703). If attacked, the buddy team employs all weapon systems at the appropriate ranges (M16, M203, and hand grenade).

NOTE: If terrain is not available to set up this exercise, a defense test range may be used (Figure 3-1). The amount of ammunition and the standards should be adjusted based upon the targetry setup.

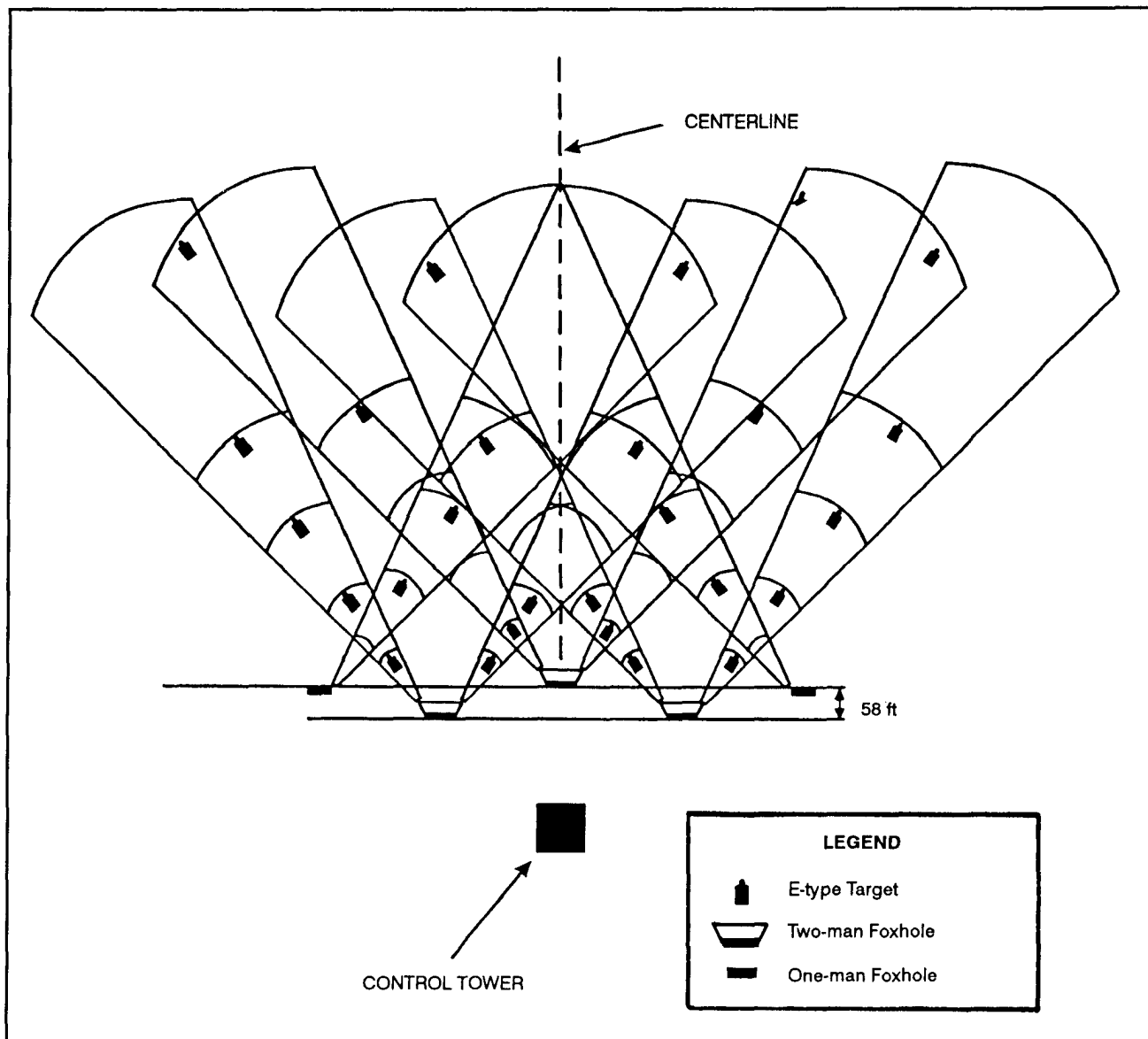

Figure 3-1. Defense test range.

b. **Exercise 1.** The fire team leader briefs his buddy teams on the tactical scenario. PVT Walker (M16) and PFC Thompson (M203) prepare their sector sketch (range cards if crew-served weapon) and sector stakes, and they begin digging their fighting positions. At a prescribed time, the team leader gives them a warning of an impending enemy attack. PVT Walker and PFC Thompson get into position and lock and load their weapons. They then engage the enemy IAW their instructions. (Engagement could take place when the enemy crosses a designated phase line, or when an oral or visual signal is given by the team leader.)

b. **Exercise 2.** A buddy team is moving down a lane (as part of a notional squad) followed by their team or squad leader. They have been briefed by their team or squad leader on the situation. They are aware that other buddy teams and fire teams are on their flanks. A shot rings out and they are told they have just come under fire by a sniper (or other enemy position) to their front. They take cover and determine where the shot came from and how they will approach the enemy using the terrain. At this point, the soldiers may or may not see the target. A sniper maybe some distance away; the soldiers may have to move toward the enemy before they can locate him. A pneumatic weapon can be used to provide realism and cue soldiers to the enemy position. The fire team leader can control the targetry during the exercise. Using proper movement techniques and communication, the buddy team begins moving toward the enemy. Soldiers may use oral commands, arm-and-hand signals, or other prearranged signals IAW Army doctrine. When the enemy is located, one of the soldiers states he is in a good position to fire. The team initiates suppressive fire and continues downrange until the threat is eliminated, or they are ordered to halt. During this exercise, the team leader may actively communicate with the buddy team, giving them visual signals and fire commands. (See Soldier's Manual of Common Tasks, Skill Level 1, task number 071-326-0502 for the conditions and standards for moving under direct fire.)

3-6. LOGISTIC SUPPORT

Logistic support covers the amount and type of equipment and ammunition needed for each phase of training at every level (Tables 3-1 through 3-5). Ammunition requirements are based on DA PAM 350-38. Equipment requirements are based on various training documents.

a. **MILES Rehearsal Ammunition Requirements.** Most blank ammunition for the rehearsal is drawn from the unit's squad, platoon, or company FTX allocations. Adding all blank allocations listed in this manual (from buddy team to platoon) equals that ammunition allocated for one FTX. Depending on how much the unit forecasts for other uses, this amount can be adjusted as desired.

b. **Live-Fire Ammunition Requirements.** The ammunition type and quantity comes from DA PAM 350-38. The unit can adjust these figures as necessary. Pyrotechnics are also addressed in DA PAM 350-38.

LIN/NSN	NOMENCLATURE	EQUIPMENT-STUDENT RATIO
Trainer	N/A	1/LANE
1265-01-075-4893	MILES, MAN-WORN LASER DETECTOR	1/1
1265-01-079-5264	MILES, M16 LASER TRANSMITTER	1/1
1265-01-092-0891	CONTROLLER GUN	1/LANE
6135-01-063-1978	BATTERY, BA 3090	3/1
6135-01-063-1978	BATTERY, BA 3090	1/CONTROL GUN
6135-00-643-1310	BATTERY, NONRECHARGEABLE 1991	3/SAAF
11835282 9353020	SMALL-ARMS ALIGNMENT (SAAF) OR SMALL-ARMS ALIGNMENT FIXTURE	4/PLATOON

**Table 3-1. Training aids and equipment
(crawl and walk phase)**

DODAC	NOMENCLATURE	EQUIPMENT-STUDENT RATIO
1330-G950	GRENADE, HAND, M18 RED SMOKE W/FUZE M201A1	1/LANE
NOTE: Some blank ammunition may be needed for demonstrations.		

Table 3-2. Ammunition requirements (crawl phase).

DODAC	WEAPON	NOMENCLATURE	EQUIPMENT-STUDENT RATIO
1305-A080	M16	CTG, 5.56-mm, BLANK, M200	20/1
1305-A075	M249	CTG, 5.56-mm, BLANK, M200 LKND W/M27	70/1
1330-G811	—	GRENADE BODY F/HAND	2/SQUAD
1330-G878	M228	FUZE, GRENADE, PRACTICE	2/SQUAD
1310-B519	M203	40-mm, PRACTICE, M385 (TP-T)	2/1
1345-K150	M18A1	MINE, APERS M81 INERT W/ACC	1/TEAM
1330-G950	—	HG RED SMOKE, M18	2/PLATOON
RESOURCE DRAWN FROM STRAC: A080 Squad, PLT, CO FTX/STX, Table 5-30, page 89. A075 Squad, PLT, CO FTX/STX, Table 5-28, page 88. B519 Squad, PLT, LFX, Table 5-34, page 90.			

Table 3-3. Ammunition requirements (walk phase).

LIN/NSN	NOMENCLATURE	EQUIPMENT-STUDENT RATIO
1265-01-075-4893	MILES, MAN-WORN LASER DETECTOR	1/1
1265-01-092-0891	CONTROLLER GUN	1/LANE
6135-01-063-1978	BATTERY, BA 3090	3/1
6135-01-063-1978	BATTERY, BA 3090	1/CONTROL GUN

Table 3-4. Training aids and equipment (run phase).

DODAC	WEAPON	NOMENCLATURE	EQUIPMENT-STUDENT RATIO
1305-A059	M16A2	CTG, 5.56-mm, BALL, M855 10/CLIP	20/1
1305-A064	M249	CTG, 5.56-mm, 4 BALL M855/TRACER M856 LKD	70/1
1330-G811		GRENADE BODY F/HAND	1/1
1330-G878	M228	FUZE, GRENADE, PRACTICE	1/1
1310-B519	M203	40-mm, PRACTICE, M385 (TP)	2/1
1345-K150	M18A1	MINE,,APERS M81 INERT W/ACC	1/TEAM
1330-G950		HG RED SMOKE, M18	2/PLATOON
RESOURCE DRAWN FROM STRAC: A059 Fire and Movement, Table 5-30, page 89. A064 Fire and Movement, Table 5-28, page 88. B519 Squad, PLT, LFX, Table 5-34, page 90.			

Table 3-5. Ammunition requirements (run phase).

CHAPTER 4

FIRE-TEAM TRAINING

This chapter provides information for live-fire training at the fire-team level, culminating in an LFX. Fire-team training should take place at the platoon level. Examples of resource requirements are provided to assist the unit in the planning and preparation of training.

Preparation for the LFX requires different levels of training by different units. The commander may decide to develop special live-fire training for his fire teams, or he may decide to eliminate fire-team training in favor of more squad training. If he decides to strengthen the fire team, several options are available. When training the fire team, the fire-team leader normally participates in engaging targets. In addition, he may sometimes relay fire commands and other instructions from the squad leader to his team.

4-1. INTRODUCTION

A fire team is the smallest maneuver element that has command and control. By incorporating the React to Contact and Break Contact battle drills within a fire-team exercise, the unit can practice command and control processes in addition to other training.

a. The fire team's LFX integrates collective fires with collective movement techniques. The soldier must focus on the collective group and his fire-team leader's interaction with the squad leader.

b. Seldom does a fire team execute a mission alone. However, training the fire team in an LFX consisting of the basics in command and control is critical in order to make squad and platoon live fires more efficient and productive. By introducing fire control techniques (fire commands, fire control measures, lifting and shifting fires, and fire discipline), unit leaders lay the foundation for the LFX. The LFX should take place in a controlled environment. This allows the leader to focus training on a limited number of collective live-fire tasks.

c. A small area is needed to set up the LFX. A known-distance (KD) range can be used to train fire teams. These fire teams can train individually or as part of the squad. Offensive training (maneuver) will occupy most of the training time.

NOTE: The defense will not be discussed here for the fire team.

4-2. OBJECTIVES

Fire-team training has many objectives. Although some training objectives may appear similar for each element, they are different. (For example, training command and control at fire-team level is vastly different than at battalion level.) Training objectives at fire-team level are:

- Introduction of basic principles of coordinated movement with other elements (fire teams).
- Communication (continued reinforcement of oral communication and arm-and-hand signals, and the addition of visual signals).
- Suppressive fire using weapons normally at this level (M16 rifle, M203 grenade launcher, M249, hand grenades, and so on).
- Use of terrain.
- Target detection.
- Target engagement (fire control).

4-3. FOCUS

Fire-team training should focus on positions, volume of fire, fire distribution, application of fire, fire control, and fire discipline.

a. **Positions.** The fire team leader must ensure that individual positions are properly spaced (based on terrain) and offer concealment and protection for both the offense and defense. Usually the squad will have a base soldier for the squad to form on. The following points should be considered:

(1) Each soldier should have visual contact with the soldier on his left and right.

(2) Positions should be properly aligned to cover their sectors, and their fields of fire should interlock. The leader must ensure no one is in a position where they may be accidentally shot.

b. **Volume of Fire (Intensity).** In combat, the volume of fire is usually high at first (to gain fire superiority), then decreases to a lower level.

(1) Ammunition and magazines must be clean and serviceable.

(2) Rapid reloading is critical. This can be learned through SOPs and rehearsals, and by having two or three tracer rounds as the last few rounds in the magazine to warn the firer the magazine will soon be empty.

c. **Fire Distribution.** Fire distribution (Figure 4-1) is normally covered by a unit SOP and supplemented as necessary by the team leader and the squad leader. For example, the SOP may direct soldiers to fire at targets to their front, or within a 20-degree arc from their position. The squad leader may change that due to the situation and tell M203 gunners to fire into dead space on the right flank, or tell the M249 gunners to fire at light

vehicles, enemy machine guns, and so on. (This topic also should be covered in platoon operations orders.)

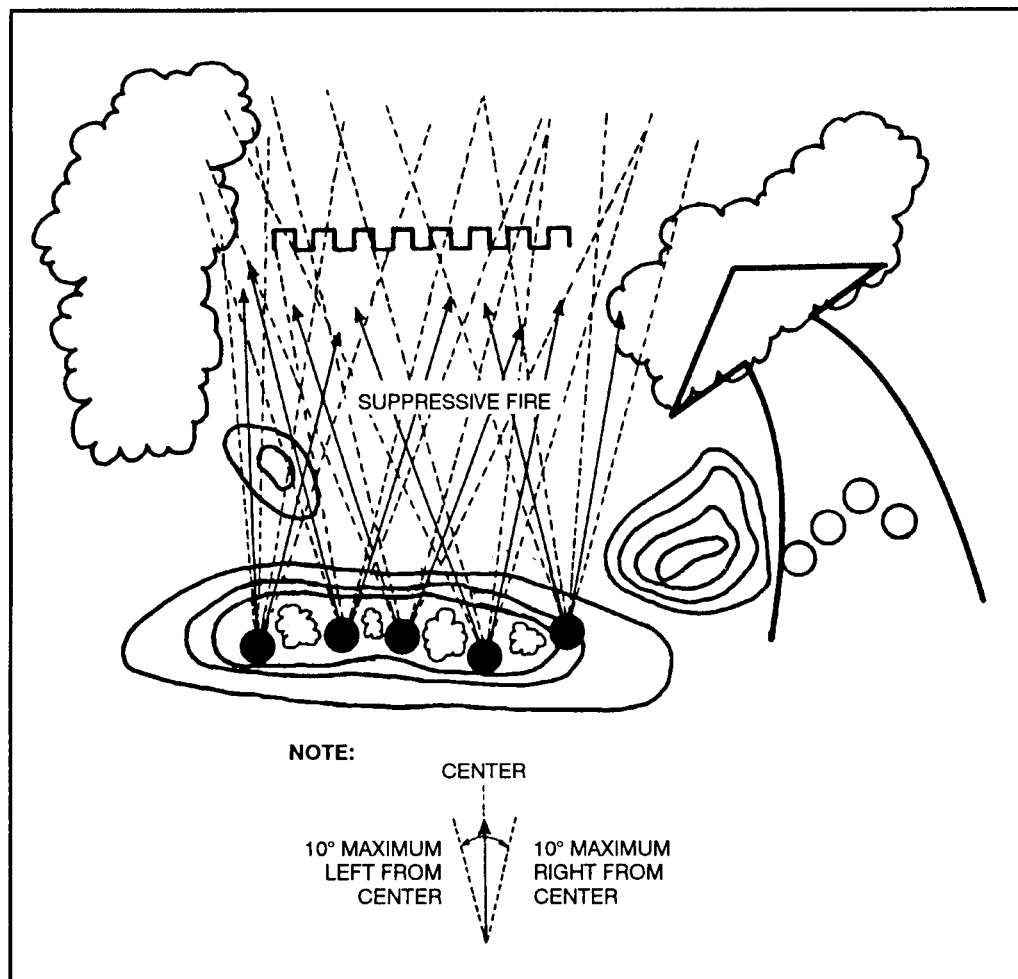

Figure 4-1. Fire distribution.

d. **Application of Fire.** Fire can be applied as *concentrated fire* or *distributed fire*. Concentrated fire is directed by the fire team at a point target. Distributed fire is delivered in width and depth to cover an area in which the enemy is known or suspected to be.

NOTE: This is a method of engaging targetry and should not be confused with fire distribution, which controls and measures collective fires on the threat array.

e. **Fire Control.** Fire control includes fire commands (alert, direction, target description, range, method of fire) and fire control measures (sectors of fire, engagement areas, TRPs, phase lines). (See Appendix I.) Fire control can be executed by using oral signals, arm-and-hand signals, prearranged signals, personal contact, and SOPs. Fire control allows the

fire team to select and designate targets, open fire at the desired instant, adjust fire, control rate of fire, shift to other targets, and cease fire.

f. **Fire Discipline.** Fire discipline means firing IAW SOPs and/or leader instructions. Fire should be directed at known targets to conserve ammunition for the duration of the battle.

4-4. TRAINING SEQUENCE

The normal training sequence is crawl, walk, and run.

a. In the crawl phase (dry fire), the fire team is oriented to the terrain. As they walk through the exercise, they are reminded of combat basics through briefings and demonstrations. Fire commands and fire control measures are also discussed and rehearsed.

b. In the walk phase (rehearsal), the fire team is challenged to demonstrate their understanding of the concepts. Using MILES allows a force-on-force exercise, which increases realism and helps identify weaknesses.

c. When successful in the walk phase, the team moves to the run phase (live fire). Again, the fire team uses MILES to increase training realism. The controller uses the control gun to cause a "near miss" when the soldier violates a movement principle or a "kill" when he commits an unsafe act.

4-5. EXAMPLE RATTLE-BATTLE DRILL (KNOWN-DISTANCE RANGE)

In a rattle-battle drill, two fire teams can train together or separately. They should be supervised by a squad leader or senior NCO with a MILES control gun. (This individual also controls commands to the target pits.) Soldiers must keep in mind that this is fire-team training, not squad training. The team leader directs his team; if present, the squad leader observes, assists, and provides commands to the fire-team leader.

a. The commander decides to spend a minimum amount of time training his fire teams in fire control before moving into squad live-fire training. Before the day of training, all leaders complete a walk-through (TEWT) on the range where the exercise will take place.

b. The unit draws weapons and MILES equipment, and is then transported to a known-distance range. The fire teams are first briefed on the rules of engagement, then they conduct a walk-through of the exercise. Once the walk-through is complete, the fire teams collect their ammunition, and two of them move up to the starting point.

c. As the first series of targets appear, the squad leader initiates the exercise by giving the proper signal and by relaying fire commands to the team leaders. The fire team may move as a unit or by buddy team depending on the mission and the unit's training objectives. (In Figure 4-2, the fire team moves by buddy-team bounds.) One buddy team (Team 1)

lays a base of fire while the other (Team 2) moves to the next fire point. (This can be a marked location or a predesignated distance.)

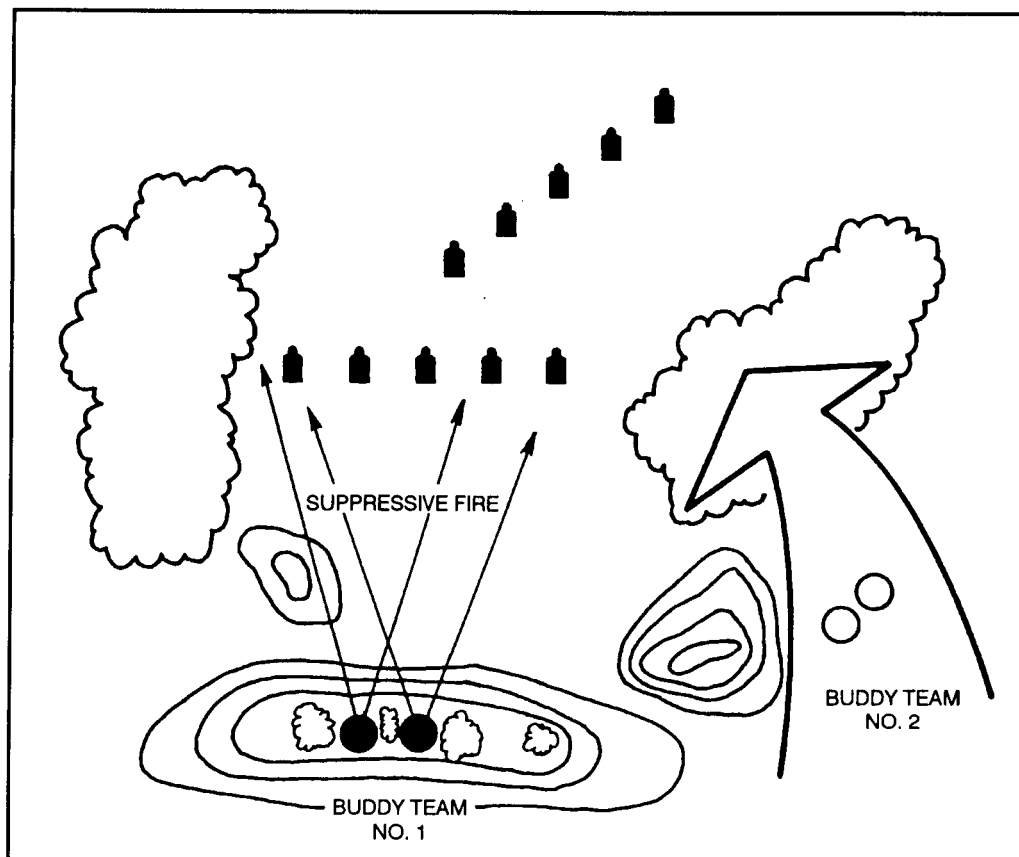

**Figure 4-2. Fire team rattle-battle course
(buddy-team movement).**

d. The next series of targets appear after Team 2 is in position. Team 2 engages the targets while Team 1 moves to the next firing point. This continues as desired.

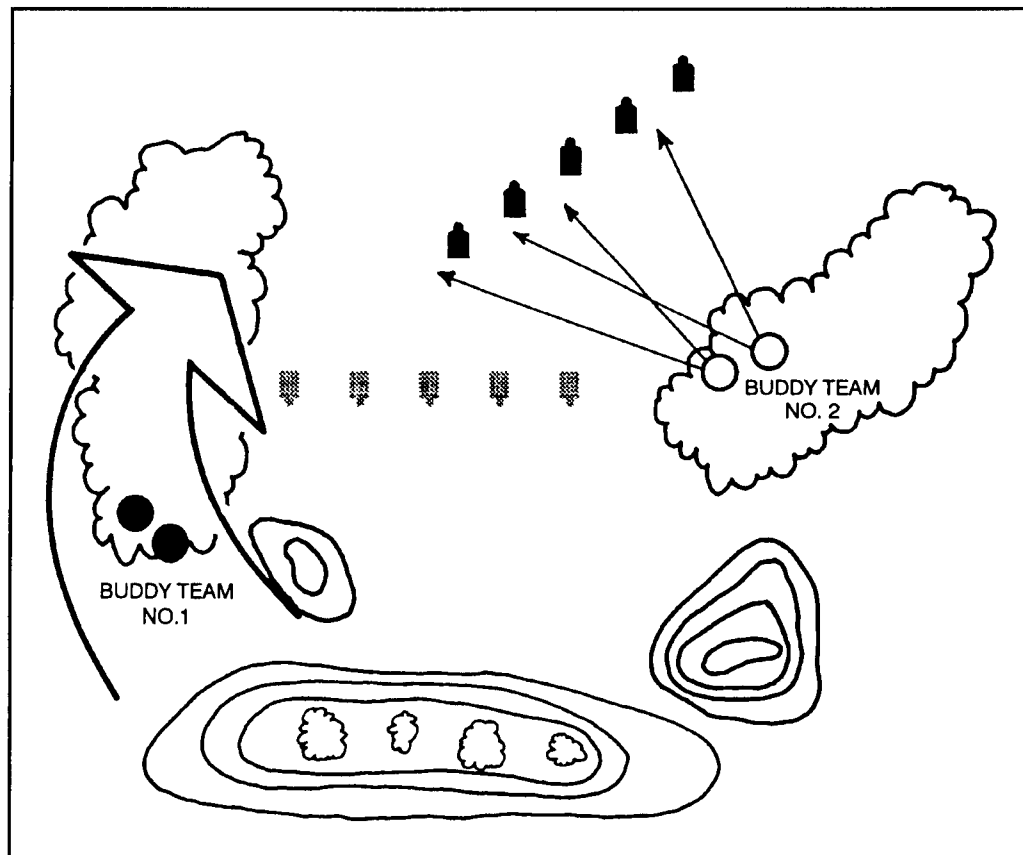

Figure 4-2. Fire team rattle-battle course
(buddy-team movement) (continued).

e. While the exercise is taking place, the other teams support range requirements (target pits, ammunition breakdown, and so on) and perform concurrent training. As each team finishes the LFX, the "squad leader and platoon leader conduct an AAR focusing on training goals—for example, fire control, fire discipline, fire distribution, and so on. (See Chapter 5, paragraph 5-9 for more information about AARs.)

4-6. LOGISTIC SUPPORT

Logistic support includes the amount and type of equipment and ammunition available for each phase of live-fire training at fire-team level—whether crawl (dry fire/walk-through), walk (rehearsal with MILES), or run (live fire) (Tables 4-1 through 4-6). The ammunition requirements are based on DA PAM 350-38. The equipment requirements are based on various training documents. These

requirements will be adjusted to the unit's training objectives based on METL and METT-T.

a. **MILES Rehearsal Ammunition Requirements.** Most blank ammunition for the rehearsal is drawn from the unit's squad, platoon, or company FTX allocations. Adding all blank allocations listed in this manual (from buddy team to platoon) equals that ammunition allocated for one FTX. Depending on how much the unit forecasts for other uses, this amount can be adjusted as desired.

b. **Live-Fire Ammunition Requirements.** The ammunition type and quantity comes from DA PAM 350-38. The unit can adjust these figures as necessary. The quantity of some ammunition can be increased by integrating allocations for other training events as long as those training events are addressed in the LFX. Pyrotechnics are also addressed in DA PAM 350-38.

LIN/NSN	NOMENCLATURE	EQUIPMENT-STUDENT RATIO
Trainer	N/A	1/LANE
1265-01-075-4893	MILES, MAN-WORN LASER DETECTOR	1/1
1265-01-079-5264	MILES, M16 LASER TRANSMITTER	1/1
1265-01-092-0891	CONTROLLER GUN	1/LANE
6135-01-063-1978	BATTERY, BA 3090	3/1
6135-01-063-1978	BATTERY, BA 3090	1/CONTROL GUN
6135-00-643-1310	BATTERY, NONRECHARGEABLE 1991	3/SAAF
11835282 9353020	SMALL-ARMS ALIGNMENT (SAAF) OR SMALL-ARMS ALIGNMENT FIXTURE	4/PLATOON

Table 4-1. Dry-fire training aids and equipment (crawl).

DODAC	NOMENCLATURE	EQUIPMENT-STUDENT RATIO
1330-G950	HG, RED SMOKE M18	2/PLATOON
NOTE: Some blank ammunition may be needed for demonstrations.		

Table 4-2. Dry-fire ammunition requirements (crawl).

LIN/NSN	NOMENCLATURE	EQUIPMENT-STUDENT RATIO
Trainer	N/A	1/LANE
1265-01-075-4893	MILES, MAN-WORN LASER DETECTOR	1/1
1265-01-079-5264	MILES, M16 LASER TRANSMITTER	1/1
1265-01-092-0891	CONTROLLER GUN	1/LANE
6135-01-063-1978	BATTERY, BA 3090	3/1
6135-01-063-1978	BATTERY, BA 3090	1/CONTROL GUN
6135-00-643-1310	BATTERY, NONRECHARGEABLE 1991	3/SAAF
11835282 9353020	SMALL-ARMS ALIGNMENT (SAAF) OR SMALL-ARMS ALIGNMENT FIXTURE	4/PLATOON

Table 4-3. Rehearsal training aids and equipment (walk).

DODAC	WEAPON	NOMENCLATURE	EQUIPMENT-STUDENT RATIO
1305-A080	M16	CTG, 5.56-mm, BLANK, M200	20/1
1305-A075	M249	CTG, 5.56-mm, BLANK, M200 LKND W/M27	70/1
1330-G811		GRENADE, BODY F/HAND	2/SQUAD
1330-G878	M228	FUZE, GRENADE, PRACTICE	2/SQUAD
1310-B519	M203	40-mm, PRACTICE, M385 (TP-T)	2/1
1345-K150	M18A1	MINE, APERS M81 INERT W/ACC	1/TEAM
1330-G950		HG RED SMOKE, M18	2/PLATOON
RESOURCE DRAWN FROM STRAC: A080 Squad, PLT, CO FTX/STX, Table 5-30, page 89. A075 Squad, PLT, CO FTX/STX, Table 5-28, page 88. G878 Squad, PLT, LFX, 8/Squad, 8 Events, Table 5-41, page 92. B519 Squad, PLT, LFX, 24 TP/WPN, 8 Events, Table 5-34, page 90.			

Table 4-4. Rehearsal ammunition requirements (walk).

LIN/NSN	NOMENCLATURE	EQUIPMENT-STUDENT RATIO
N/A	CONTROLLER	1/SQUAD
1265-01-075-4893	MILES, MAN-WORN LASER DETECTOR	1/1
1265-01-079-5264	MILES, M16 LASER TRANSMITTER	1/1
1265-01-092-0891	CONTROLLER GUN	1/CONTROLLER
6135-01-063-1978	BATTERY, BA 3090	3/1
6135-01-063-1978	BATTERY, BA 3090	1/CONTROLLER GUN
6135-00-643-1310	BATTERY, NONRECHARGEABLE 1991	3/SAAF
11835282 9353020	SMALL-ARMS ALIGNMENT (SAAF) OR SMALL-ARMS ALIGNMENT FIXTURE	4/PLATOON

Table 4-5. Live-fire training aids and equipment (run).

DODAC	WEAPON	NOMENCLATURE	EQUIPMENT-STUDENT RATIO
1305-A059	M16A2	CTG, 5.56-mm, BALL, M855 10/CLIP	110/1
1305-A063	M16A2	CTG, 5.56-mm TRCR M856 CARTON PACK	20/1
1305-A064	M249	CTG, 5.56-mm, 4 BALL M855/1 TRACER M856 LKD	430/1
1330-G811	—	GRENADE, BODY F/HAND	2/SQUAD
1330-G878	M228	FUZE, GRENADE, PRACTICE	2/SQUAD
1310-B519	M203	40-mm, PRACTICE, M385 (TP)	18/1
1310-B535	M203	40-mm, WHITE STAR PARA ILLUM, M58A1	6/1
1345-K150	M18A1	MINE, APERS M81 INERT W/ACC	1/TEAM
1330-G950	—	HG RED SMOKE, M18	*
1330-G930	—	HG, HC AN-M8	*
RESOURCE DRAWN FROM STRAC (not IAW SQD/PLT live fire): G878 Squad, PLT, LFX, 8/Squad, 8 Events, Table 5-41, page 92. *Resourced in DA PAM 350-38, Chapter 8, Pyrotechnics.			

Table 4-6. Live-fire ammunition requirements (run).

CHAPTER 5

SQUAD TRAINING

This chapter provides information for training the infantry squad, culminating in an LFX. Squad LFXs are normally resourced and controlled by the company. Examples of resource requirements are provided to assist the unit in its planning process.

The squad LFX is the culmination of all previous training. It integrates planning rehearsals, MILES exercises, and all other training the unit has conducted. The soldier's anticipation and morale are intensified. The unit leadership must ensure that this is a realistic, well-planned exercise.

5-1. INTRODUCTION

This is the first level of training that involves the unit. Here, ARTEP MTP tasks are tied together and STXs are conducted. The maneuver box is used instead of a structured range. The maneuver box concept allows the subordinate leader to select his movement route and direction of approach to an objective (within his assigned sector). It gives him a sense of independence and freedom of action. It also reinforces the seriousness of safety and control and is more realistic.

5-2. OBJECTIVES

Squad training has many objectives. These include:

- Reinforcement of principles of command and control. (See Chapter 2.)
 - (1) Reinforcement of concepts of supporting fire, base of fire, and synchronization of fires.
 - (2) Reinforcement of concepts of starting, stopping, and lifting and shifting fires.
 - (3) Concentration on maneuver (to include security and safety), fire control measures, and fire discipline.
- Communication. (Communication is the linchpin of synchronization.)
- Weapon system integration using organic and nonorganic weapons normally at this level (M16 rifles, M203 grenade launchers, M249s, grenades, Claymores, and so on).

- Completion of a fire support plan. (This includes calling for and adjusting indirect fire.)
- Use of terrain.
- Target identification, acquisition, and engagement (emphasis on fratricide prevention).

5-3. FOCUS

Squad training should focus on positions, volume of fire, fire distribution, application of fire, fire control, and fire discipline. (See Chapter 4, paragraph 4-3 and Appendix I for more information.)

a. Positions. Squad leaders must ensure individual positions are properly spaced, offer cover and concealment, and have interlocking fires for both the offense and defense. The following points should be considered:

(1) Each soldier should have visual contact with the soldier on his left and right.

(2) Positions should be properly aligned to cover their sectors. No one should be located in a position where he may be accidentally shot.

b. Volume of Fire (Intensity). In combat, the volume of fire is usually high at first to gain fire superiority, then decreases to a lower level.

(1) Ammunition and magazines must be clean and serviceable.

(2) Rapid reloading is critical. This can be learned through SOPs and rehearsals, and by having a tracer round as the last or next to last round in the magazine to warn the firer the magazine is empty.

c. Fire Distribution. Fire distribution is normally covered by a unit SOP and supplemented as necessary by the team leader and the squad leader.

d. Application of Fire. Fire can be applied as concentrated fire or distributed fire.

(1) Concentrated fire is directed at a point target.

(2) Distributed fire is delivered in width and depth to cover an area in which the enemy is known or suspected to be.

NOTE: This is a method of engaging targetry and should not be confused with fire distribution, which controls and measures collective fires on the threat array.

e. Fire Control. Fire control includes fire commands (alert, direction, target description, range, method of fire) and fire control measures (sectors of fire, engagement areas, TRPs). It can be accomplished by using oral signals, arm-and-hand signals, prearranged signals (to include whistles, flares, and so on), personal contact, and SOPs. Fire control allows the unit to select and designate targets, open fire at the desired

instant, adjust fire, control the rate of fire, shift to other targets, and cease fire (lift). (See Appendix I for more information.)

f. **Fire Discipline.** Fire discipline means firing IAW SOPs and or leader instructions. Fire should be directed by the squad leader through verbal commands and tracer fire.

5-4. PLANNING

Before any unit starts planning an LFX, leaders must determine the individual and collective tasks to be incorporated into the exercise. They base this on the unit commander's assessment in conjunction with the unit's METL. Once the tasks have been identified, planning begins. (Figure 5-1 shows an example of a squad training plan.) All planning must include the following duties:

- a. Assign a project officer.
- b. Contact range control for a description of training areas and regulations for conducting an LFX.
- c. Develop a training plan that includes tasks to be trained, support requirements (ammunition, transportation, training area/range requirements, medics, other logistic considerations), and time/rotation schedule. Use historical data and the experience of other units to gather information to help in planning the exercise.
- d. Develop the tactical plan. Incorporate a threat scenario that helps the unit achieve its training goals. (ARTEP MTPs identify tasks for the OPFOR to be evaluated.)
- e. Develop the live-fire plan to include all SDZ overlays. (A scenario that explains maneuver and where each contact will occur should be organized chronologically, then submitted to range control.)
- f. Reconnoiter terrain.
- g. Conduct support training (OCs, MILES, safety, AAR).
- h. Coordinate with outside agencies for training aids, controllers, MILES equipment, and other logistical support needed.

NOTES: 1. MILES equipment is an effective training aid if it is zeroed. Enough time should be allocated to properly zero MILES.

2. The MILES transmitter should be fastened as tightly as possible to the barrel of the weapon. Empty cardboard boxes (blank ammunition boxes) can be placed between the transmitter and the barrel to ensure a tight fit.

SUBJECT: Training Plan
Squad Training 27-31 January 1992

UNIT: A/1/508

1. TRAINING OBJECTIVE: To conduct squad-level training and gain proficiency in those squad collective tasks that support the following platoon missions: area reconnaissance, raid, movement to contact, and ambush.

2. TRAINING CONCEPT: A/1/508 will conduct an airborne insertion on 271900 JAN into McKenna DZ. Each platoon will assemble and infiltrate by squads 12-17 km north to designated platoon linkup points and occupy platoon patrol bases. Each platoon will rotate between three situational training exercise (STX) lanes to conduct squad training. The ambush STX lane will be in the 7, 8, 9 areas; the squad reconnaissance/platoon raid STX lane will be in the 10, 13 areas; and the movement to contact STX/LFX lane will be at Ware Range. Each squad will have 24 hours to receive orders from the platoon leader, conduct TLPs, execute the mission, retrain if necessary, and infiltrate to the next STX lane. Upon completion of training on 302400 JAN, each squad will move to an extraction point, load trucks, and return to the company area to recover.

3. COLLECTIVE TASKS: The following collective tasks will be trained:

TASK	REFERENCE
Assault	7-3/4-1011
Overwatch	7-3/4-1007
Knock out bunker	7-3/4-1012
Point ambush	7-3/4-1020
Move tactically	7-3/4-1022
Cross danger area	7-3/4-1028
Occupy ORP	7-3/4-1041
Occupy patrol base	7-3/4-1044
Perform linkup	7-3/4-1064
Infiltrate/exfiltrate	7-3/4-1065
Reconnoiter zone	7-3/4-1043
Reconnoiter area	7-3/4-1042
Prepare for combat	7-3/4-1046
Consolidate/reorganize	7-3/4-1047

4. INDIVIDUAL TASKS: See ARTEP 7-8-MTP, pages 2-12 through 2-43 for the individual tasks to be trained.

Figure 5-1. Example squad training plan.

5. TIME SCHEDULE:

TIME	UNIT	ACTIVITY
270001	All	TOT McKenna DZ
2100-2400	All	Squad infiltrations
280001-0800	1st	Infiltrate/establish patrol base vicinity GL101978
	2d	Infiltrate/establish patrol base vicinity GL092996
	3d	Infiltrate/establish patrol base vicinity GL078951
0800-2400	1st	MTC STX/LFX
	2d	Ambush STX
	3d	Squad reconnaissance/platoon raid STX
290001-0800	1st	Infiltrate/establish patrol base vicinity GL078951
	2d	Infiltrate/establish patrol base vicinity GL101978
	3d	Infiltrate/establish patrol base vicinity GL092996
0800-2400	1st	Squad reconnaissance/platoon raid STX
	2d	MTC STX/LFX
	3d	Ambush STX
300001-0800	1st	Infiltrate/establish patrol base vicinity GL092996
	2d	Infiltrate/establish patrol base vicinity GL078951
	3d	Infiltrate/establish patrol base vicinity GL101978
0800-2400	1st	Ambush STX
	2d	Squad reconnaissance/platoon raid STX
	3d	MTC STX/LFX
310001	1st	Move to exfiltration point vicinity GL109995
	2d	Move to exfiltration point vicinity GL099946
	3d	Move to exfiltration point vicinity GL103977
0300-UTC	All	Truck to company area and recover

Figure 5-1. Example squad training plan (continued).

- 6. OPFOR PLAN:**
- A. 1- to 9-man element to conduct defense and patrolling for reconnaissance and raid objective.
 - B. 1- to 5-man element to conduct hasty defense for movement to contact blank fire.
 - C. 1- to 4-man element to move tactically and react to near ambush for the ambush lane.
7. **AAR:** The platoon leader and PSG will lead AARs for their squads. AARs will be IAW ARTEP 7-8-MTP.
8. **SAFETY:** See Company A's safety SOP.
- 9. TRAINING SUPPORT:**
- A. *Ammunition:* TBA
 - B. *MILES:* MILES equipment will be used for all missions. Only the torso harnesses will be used for the movement to contact LFX. All OPFOR personnel will wear MILES.
 - C. *Medical:* Each platoon will deploy with their assigned medic.
 - D. *Rations:* Chow cycle will be AAC/ACC/ACC/ACC.
 - E. *Resupply:* Water and MREs will be received with the morning meal. The squad leader must request and coordinate resupply of other classes of supply through the PSG after he receives his orders. The PSG will relay the requests to the XO and coordinate a drop time and location.
 - F. *Training aids:* The reconnaissance/raid objective will be constructed using a GP small tent and a supply cache.
10. **LEADER'S TEWT:** 271000 JAN 92.

Figure 5-1. Example squad training plan (continued).

5-5. SETUP

All installations have different range regulations governing the conduct of LFXs. Temporary impact areas for maneuver LFXs can be approved by the commanding general (AR 635-63). For a squad, a recommended maneuver box would be one that consists of a 5- by 2-kilometer box. This allows the unit to employ its different weapon systems as long as they are within the planned SDZs. Each weapon system's limits in terms of azimuth and distance must be considered. These limits are identified for each weapon system at every point from which the weapon is fired. At any given location in the maneuver box, left and right limits should exist that can be expressed in degrees or roils. All leaders must understand these limits and incorporate them into the TEWT and the walk-through or rehearsal before the LFX is executed. (See Appendix G and AR 385-63 for more detailed information on SDZs.)

a. Leaders must adjust scenarios based on range restrictions, terrain, and training objectives. Every possible attempt should be made to

incorporate all types of weapon systems at their maximum ranges. The maneuver box size needed for a squad LFX varies based on mission. (For example, a movement to contact normally requires more area than an ambush.) When developing a live-fire area, leaders should plan for no restrictions at first, then adjust as required to support the mission, keeping it tactically sound.

b. **Doctrine must support the target array.** Leaders should use a scenario to replicate threat dispositions. When planning the scenario, leaders should consider the following:

(1) Enemy targets must engage the unit at the proper distance.

(2) Enemy targets must be located in proper relation to the rest of the enemy positions.

(3) Enemy targets must be located in a realistic area using terrain (not in an open field but behind a tree in a fighting position). For example, on a movement to contact an observation post could be placed between 200 to 500 meters away from where the unit will be engaged, 200 meters in front of the enemy squad it supports (which is part of a notional platoon), in hasty fighting positions in a tree line.

5-6. EXECUTION OF THE LIVE-FIRE EXERCISE

The execution of a maneuver box LFX is much like any other training exercise. Although live ammunition increases concern, experience breeds confidence. While squad leaders do not normally participate in fires, they frequently designate targets and control fires by using tracers as a method of command and control of their fire teams.

a. **Safety Briefing.** A safety briefing should always be conducted before the LFX. (A sample briefing is included in Appendix A.)

b. **Risk Assessment.** This is a leader's (commander) responsibility. The unit must be assessed to determine if a condition exists that will make the LFX hazardous (lack of sleep, lack of experience with a complex/dangerous task, and so on). (A sample risk assessment can be reviewed in Appendix A.)

c. **Leader Participation.** The chain of command should always participate when possible. This includes both command and logistic play. In a squad exercise, the platoon leader can provide input and receive reports through radio communications with his squad leaders. (This is how it will be done in combat.) In the LFX, the platoon leader can direct action as a teaching point or just allow the squad to maintain momentum. In addition, the platoon leader strengthens his working relationship with his squad leaders and gains a first-hand knowledge of his NCO's experience and capabilities. The platoon leader should not be an evaluator. (This provides an opportunity for the squad to be observed subjectively as opposed to objectively.)

5-7. OBSERVER-CONTROLLERS

The OCs assist the unit in contributing to the realism of force-on-force and LFXs by coordinating indirect fires, assessing casualties, and controlling targetry. In addition, they assist the unit in the operation of MILES equipment and in stopping unsafe acts. (See Appendix H.) OCs allow the chain of command to focus on the battle without unrealistic or artificial distractions. They are doctrinal experts who help the unit analyze its performance through the use of an AAR. The personnel used in this capacity must be of the highest quality. While they are used at Army Training Centers and by divisions in large-scale exercises, OCs can be provided for small-unit training by battalions and companies in coordination with sister units. OCs should assist the unit, not evaluate it. If OCs cannot be provided from external assets, the chain of command can perform some of those functions (the company commander and first sergeant for a platoon LFX). OCs are usually not used at the level, however, they can be helpful if assets are available.

5-8. ASSESSMENT

Assessment is a major part of the LFX. It is based on MTP standards, FMs 7-7 and 7-8, and marksmanship data. AARs should be used to discuss tasks that need improvement. All soldiers should note problems and successes, and discuss these in the AAR. (See Appendix J.)

a. Maintaining a positive environment is important for learning. The LFX assessment is not a critique. Therefore, empirical data should be used to merely assist in identifying general strengths and weaknesses, not to pronounce pass or fail. The fact that variable conditions affect each LFX differently should be remembered when compiling data. If a unit fails to perform to standard, the LFX should be repeated.

b. MTPs should be used as the primary source of assessments. Quantitative MTP standards may be difficult to measure in LFXs, especially without target MILES shootback capability. As a whole, MTP subtasks are much more subjective and easier to measure (go/no-go).

c. Field manuals also assist the leader in assessing his unit. They sometimes offer alternative concepts and ideas in an approach to a tactical problem. Field manuals also go into much more depth than an MTP and can be used to assess problem areas.

d. Marksmanship data should be analyzed in every LFX. Fire control measures, fire commands, fire discipline, suppression, lifting and shifting fires, and fire distribution assist the leader in identifying potential problems. Use of marksmanship data should be subjective. When using multiple weapon systems, the OC may not always be able to tell what type of projectile hit the target (grenade, AT4, M16 rounds, or M249 rounds). Chapter 2 provides a list of variables that may affect collective

marksmanship. This information should be assessed carefully. It should be used to identify general strengths and weaknesses.

e. The chain of command should also conduct a separate, private assessment and counseling of the unit leader. This assists the leader in identifying his own strengths and weaknesses.

f. OCs, leaders, and the soldiers themselves are used in the assessment process. Tools that can assist this process are video cameras, polaroid cameras, sand tables, charts, diagrams, and other audio or visual aids.

5-9. AFTER-ACTION REVIEWS

The AAR is one of the most important aspects of training. It allows a unit's strengths and weaknesses to be discovered and discussed so training goals can be set for the future. The AAR should be conducted at the lowest levels so all soldiers have input and recognize their own strengths and weaknesses. Therefore, training has legitimacy and the support of all soldiers. The success of an AAR depends mostly on the conductor who should be thoroughly trained and rehearsed in giving AARs, and should be an expert in unit tactics. The AAR should not only concentrate on the separate tasks and subtasks of the mission, but also on each battlefield operating system (BOS) and the battle as a whole. (See FM 25-101.)

5-10. SQUAD MISSION

This paragraph presents an exercise scenario based on ARTEP MTP missions and standards. The commander should change, add, or delete missions based on his unit's METL and METT-T.

MISSION: 1st SQD, 1st PLT, B CO, 2/22 INF conducts a movement to contact NLT 102000 Jul 92 to reestablish contact with enemy forces along Axis Blue.

a. **Maneuver Box and Targetry.** (See Appendix C.)

(1) Threat and friendly targets can be the standard one-dimensional Army targets or three-dimensional life-size targets constructed of plywood/pressboard with metal spring joints, clothed in OPFOR uniforms. Targets are activated by an OC (or unit leader) using an electronic transmitter. When a target is hit, a mechanism is activated causing the target to drop to the ground. If the OC feels the target is suppressed effectively, he may drop it. If suppression stops before maneuvering over a specific area, the OC may raise the target at his discretion.

(2) Targetry is placed according to threat doctrine. It will engage the friendly forces at the appropriate range with respect to the capabilities of the enemy weapons and terrain.

(3) Pneumatic firing devices with MILES transmitters attached to a vehicle windshield motor create a fan of return fire. This "fire" is

supplemented by the controllers when soldiers commit an unsafe or unrealistic act. All targetry equipment should be hardened as much as possible to protect it from weapon systems employed in the LFX.

(4) For a movement to contact, the squad maneuver box should be about 1,000 to 2,000 meters long and 1,000 meters wide. This does not include an assembly area or the SDZs that merge into the impact area. The size of the maneuver box can be adapted to the mission and terrain. (An ambush or attack mission might require a box 1,000 meters long by 1,000 meters wide.)

b. Scenario.

(1) **General situation.** The battalion has seized key terrain within its area of operations. Contact with enemy elements has been broken. Intelligence reports indicate the enemy is retreating in small groups and will defend in 2- to 3-man elements to slow friendly forces. The enemy is believed to have the capability to counterattack in regimental strength within the next 36 hours.

(2) **Special situation.** The company is in an assembly area when ordered to conduct a movement to contact, cross the LD and orient on three separate march objectives. The company commander's FRAGO specifies that enemy squads or larger formations will not be bypassed unless ordered.

(3) **Phase I.** The squad, as part of the company movement to contact, comes under sniper fire or fire from an OP. The squad executes the react to contact battle drill and develops the situation. It continues the movement to contact.

(4) **Phase II.** The squad continues the mission and comes under indirect fire. It executes the react to indirect fire battle drill.

(5) **Phase III.** The squad then comes under direct small arms fire from an OPFOR OP. It executes the react to contact battle drill, develops the situation, and neutralizes the position. The squad consolidates and reorganizes and continues the mission.

(6) **Phase IV.** The squad is engaged by an enemy squad and executes the react to contact battle drill. If the squad leader determines he cannot take the position, he establishes a base of fire to fix the enemy and contacts the platoon leader for further instructions.

(7) **Phase V.** The unit conducts an AAR IAW the tactical situation and prepares for the next mission.

c. Weapon Accommodation.

(1) Weapons systems used vary depending on the type of unit and terrain available (to accommodate necessary SDZs). The Joint Readiness Training Center (JRTC) uses up to 40-mm M203 practice rounds and AT4s on its Movement to Contact range. It also uses live Claymores in its

ambush scenario, and live grenades, mortars, artillery, and bangalore torpedoes in its deliberate attack scenario.

(2) The SDZs are based on the largest caliber ballistic weapon/munitions to be used. They are designed to provide the squad with the maximum flexibility in the selection of tactically sound movement techniques throughout the area. Specifically, they need to be plotted from the most probable axes of march that the platoon leaders might select. These axes of march can be influenced through operations orders that define boundaries, restrictive fire areas, and so on, and control which target array to activate.

(3) Using the extreme engagement limits, the maximum distance of fire is plotted to the left, right, and forward of the participating unit's line of fire. The possibility of an injury caused by friendly fire is increased on this range. Personnel must follow the safety precautions presented in the safety briefing.

5-11. LOGISTIC SUPPORT

Logistic support covers the amount and type of equipment and ammunition needed for each phase of live-fire training at squad level—whether crawl (dry fire/walk-through), walk (rehearsal with MILES), or run (live fire) (Tables 5-1 through 5-6). The ammunition requirements are based on DA PAM 350-38 using a maneuver box with no weapon caliber restrictions. The equipment requirements are based on various training documents. These requirements can be adjusted to the unit's training objectives based on METL and METT-T.

a. **MILES Rehearsal Ammunition Requirements.** Most blank ammunition for the rehearsal is drawn from the unit's squad, platoon, or company FTX allocations. Adding all blank allocations listed in this manual (from buddy team to platoon) equals that ammunition allocated for one FTX. Depending on how much the unit forecasts for other uses, this amount can be adjusted as desired.

NOTE: Additional ammunition will be needed for test fires. All weapons should be test fired if possible.

b. **Live-Fire Ammunition Requirements.** The ammunition type and quantity comes from DA PAM 350-38. The quantity of some ammunition can be increased by integrating allocations for other training events as long as those training requirements are addressed in the LFX. In some cases, live ammunition can be used instead of simulators. (For example, even though five 9-mm rounds for each platoon are allocated for the AT4 in the LFX, a yearly allocation of one live round for each firer [four for each rifle squad] exists. These live rounds can be integrated into the LFX.) Pyrotechnics are addressed in DA PAM 350-38.

LIN/NSN	NOMENCLATURE	EQUIPMENT-STUDENT RATIO
N/A	CONTROLLER	1/SQUAD
1265-01-075-4893	MILES, MAN-WORN LASER DETECTOR	1/1
1265-01-079-5264	MILES, M16 LASER TRANSMITTER	1/1
1265-01-092-0891	CONTROLLER GUN	1/CONTROLLER
6135-01-063-1978	BATTERY, BA 3090	3/1
6135-01-063-1978	BATTERY, BA 3090	1/CONTROLLER GUN
6135-00-643-1310	BATTERY, NONRECHARGEABLE 1991	3/SAAF
11835282 9353020	SMALL-ARMS ALIGNMENT (SAAF) OR SMALL-ARMS ALIGNMENT FIXTURE	4/PLATOON

Table 5-1. Dry fire training aids and equipment (crawl).

DODAC	WEAPON	NOMENCLATURE	EQUIPMENT-STUDENT RATIO
1330-G950	—	HG, RED SMOKE M18	2/PLATOON

NOTE: Some blank ammunition may be needed for demonstrations.

Table 5-2. Dry-fire ammunition requirements (crawl).

LIN/NSN	NOMENCLATURE	EQUIPMENT-STUDENT RATIO
N/A	CONTROLLER	1/SQUAD
1265-01-075-4893	MILES, MAN-WORN LASER DETECTOR	1/1
1265-01-079-5264	MILES, M16 LASER TRANSMITTER	1/1
1265-01-092-0891	CONTROLLER GUN	1/CONTROLLER
6135-01-063-1978	BATTERY, BA 3090	3/1
6135-01-063-1978	BATTERY, BA 3090	1/CONTROLLER GUN
6135-00-643-1310	BATTERY, NONRECHARGEABLE 1991	3/SAAF
11835282 9353020	SMALL-ARMS ALIGNMENT (SAAF) OR SMALL-ARMS ALIGNMENT FIXTURE	4/PLATOON

Table 5-3. MILES rehearsal training aids and equipment (walk).

DODAC	WEAPON	NOMENCLATURE	EQUIPMENT-STUDENT RATIO
1305-A080	M16	CTG, 5.56-mm, BLANK, M200	20/1
1305-A075	M249	CTG, 5.56-mm, BLANK, M200 LKND W/M27	70/1
1330-G811		BODY F/HAND GRENADE	2/SQUAD
1330-G878	M228	FUZE, GRENADE, PRACTICE	2/SQUAD
1310-B519	M203	40-mm, PRACTICE, M385 (TP-T)	2/1
	M47	DRAGON (INERT)	2/PLATOON
1345-K150	M18A1	MINE, APERS M81 INERT W/ACC	1/TEAM
1330-G950		HG RED SMOKE, M18	2/PLATOON
RESOURCE DRAWN FROM STRAC: A080 Squad, PLT, CO FTX/STX, Table 5-30, page 89. A075 Squad, PLT, CO FTX/STX, Table 5-28, page 88. G878 Squad, PLT, LFX, 8/Squad, 8 Events, Table 5-41, page 92. B519 Squad, PLT, LFX, 24 TP/WPN, 8 Events, Table 5-34, page 90.			

Table 5-4. MILES rehearsal ammunition requirements (walk).

LIN/NSN	NOMENCLATURE	EQUIPMENT-STUDENT RATIO
N/A	CONTROLLER	1/SQUAD
1265-01-075-4893	MILES, MAN-WORN LASER DETECTOR	1/1
1265-01-079-5264	MILES, M16 LASER TRANSMITTER	1/1
1265-01-092-0891	CONTROLLER GUN	1/CONTROLLER
6135-01-063-1978	BATTERY, BA 3090	3/1
6135-01-063-1978	BATTERY, BA 3090	1/CONTROLLER GUN
6135-00-643-1310	BATTERY, NONRECHARGEABLE 1991	3/SAAF
11835282 9353020	SMALL-ARMS ALIGNMENT (SAAF) OR SMALL-ARMS ALIGNMENT FIXTURE	4/PLATOON

Table 5-5. Live-fire training aids and equipment (run).

DODAC	WEAPON	NOMENCLATURE	EQUIPMENT-STUDENT RATIO
1305-A059	M16A2	CTG, 5.56-mm, BALL, M855 10/CLIP	130/1
1305-A063	M16A2	CTG, 5.56-mm TRCR M856 CARTON PACK	20/1
1305-A064	M249	CTG, 5.56-mm, 4 BALL M855/1 TRACER M856 LKD	500/1
1310-B519	M203	40-mm, PRACTICE, M781 (TP)	24/1
1310-B535	M203	40-mm, WHITE STAT PARA ILLUM, M58A1	6/1
1330-G811	—	BODY F/HAND GRENADE	2/SQUAD
1340-H708	M72A2	RKT, 35-mm SUBCAL, M73 (PRAC)	+ 4/SQUAD
1305-A358	M136	9-mm, PRACTICE, M939 F/AT4	+ 5/FIRER
	M47	DRAGON (INERT)	*
1427-PL22	M47	GUIDED MISSILE AND LAUNCHER, SURFACE ATK, PRACTICE, M223 (DRAGON)	+
1370-L367	M47	SIMULATOR, ATWESS M22	+ 2/GUNNER
1345-K143	M18A1	MINE, APERS M18A1, (INERT) W/ACC	*
1375-M028	—	BANGALOR TORPEDO M1A2	@
1330-G950	—	HG, RED SMOKE M18	*
1330-G930	—	HG, HC AN-M8	*
1330-G940	—	HG, GREEN SMOKE M18	*
1330-G955	—	HG, VIOLET SMOKE	*
* Resourced in DA Pam 350-38, Chapter 8, Pyrotechnics. + Quantities valid, assuming they won't be used at PLT level. @ Not STRAC resourced for infantry.			

Table 5-6. Live-fire ammunition requirements (run).

CHAPTER 6

PLATOON TRAINING

This chapter discusses training and preparing the platoon to complete an LFX. Platoon LFXs are normally resourced and coordinated by the battalion. Example range and resource requirements are provided.

6-1. INTRODUCTION

Each type and size unit has different training needs. The platoon focuses on different tasks than the squad. Like units train different tasks because of varying degrees of proficiency. This paragraph provides training considerations and objectives of the platoon with regard to LFXs.

a. The optimum training range is one that provides feedback and realism (life-like targetry, room to maneuver, battle sounds, and so on). A maneuver box has the most potential to meet these requirements. This concept allows the subordinate leader to select the direction of approach to an objective within his assigned sector and gives him a sense of independence and freedom of action. It emphasizes the seriousness of safety and control, and it is more realistic. However, a maneuver box may be difficult to obtain at different installations, and it takes a lot of time and effort to prepare. (The maneuver box and some alternatives are discussed in greater detail in Appendix J.)

b. When a unit conducts an LFX, the soldier can observe the unit's command and control. For this reason, the command element must be trained before the LFX. While a TEWT is important, it may not be enough. A walk-through with team leaders and above, led by the commander, can answer many questions and avoid potential problems. However, reviewing the exercise with a TEWT generally does not satisfactorily integrate the unit's weapon systems. A fire coordination exercise (FCX) can fill this void. (FM 25-4 discusses the different exercises available to the unit, based on training objectives and resources.)

6-2. OBJECTIVES

Platoon training has many objectives. These include:

- Reinforcement of principles of command and control. (See Chapter 2.)
 - Reinforcement of concepts of supporting fire, base of fire, and synchronization of fires.

- Reinforcement of concepts of starting, stopping, and lifting and shifting fires. (Everyone must know [through training and rehearsals] the signal for lift or shift. *Lift simply means to cease fire*. Shifting is more complex. It can mean shifting from one section of the objective to an adjacent section, or it can denote a total shift from the objective to an adjacent area. Additional coordination and a timed sequence of events [matrix] can apply in certain missions such as a deliberate attack.)
- Concentration on maneuver (to include security), fire control measures, and fire discipline.
- Communications using radio, wire, and signals. (Communications takes on a more significant role at platoon level. The equipment and signaling devices become more complex. For example, the task to lift and shift fires is a complicated issue that varies depending on the situation [METT-T]. The more complicated the situation, the more important communications become. Different techniques using state-of-the-art technology must be incorporated as an integral part of every LFX.)
- Weapon system integration using organic and nonorganic weapons normally at this level (M16 rifle, M203 grenade launcher, M249, grenades, Claymore mines, AT4s, mortars, artillery, and so on).
- Use of terrain.
- Target identification, acquisition, and engagement (emphasis on fratricide avoidance).

6-3. FOCUS

Platoon training should focus on positions, volume of fire, fire distribution, application of fire, fire control, and fire discipline. (These are discussed in detail in Chapter 4 and Appendix I.)

a. **Positions.** The platoon leader must ensure that squad positions are properly spaced (based on terrain) and offer concealment and protection for both the offense and defense. In addition to the information discussed in Chapters 4 and 5, the following points should be considered:

(1) Crew-served weapons should cover the most dangerous enemy avenue of approach.

(2) Indirect fires, antiarmor weapons, and other weapon systems should be integrated into the fire plan.

b. **Volume of Fire.** In combat, the volume of fire is usually high at first to gain fire superiority, then decreases to a lower level.

c. **Fire Distribution.** Fire distribution is where a unit's fires are directed and where they hit. It is normally covered by a unit SOP and supplemented as necessary by the team leader and the squad leader.

d. **Application of Fire.** Fire can be applied as concentrated fire or distributed fire.

e. **Fire Control.** Fire control includes fire commands and fire control measures. Fire control can be accomplished by using oral signals, arm-and-hand signals, prearranged signals (to include whistles, flares, and so on), personal contact, and SOPs. Fire control allows the platoon to select and designate targets, open fire at the desired instant, adjust fire, control rate of fire, shift to other targets, and cease fire. (See Appendix I.)

f. **Fire Discipline.** Fire discipline means firing IAW SOPs, leader instructions, or both. Fire should be directed at known targets to conserve ammunition for the duration of the operation.

6-4. PLANNING

Before any unit starts planning an LFX, leaders must determine the individual and collective tasks to be incorporated. This is based on the unit commander's assessment in conjunction with the unit's METL. Once the tasks have been identified, planning begins. (Figure 6-1 shows an example of a platoon training plan.) (See Chapter 5 and Appendix E for further information on planning an LFX.)

AORG-TB-A		
MEMORANDUM FOR: A CO leaders		
SUBJECT: Training plan for platoon live-fire raids, Camp Ripley, Minnesota, 23-26 September 91.		
1. TRAINING OBJECTIVE: A CO conducts platoon live-fire raids to gain proficiency on designated collective and METL tasks.		
2. TRAINING CONCEPT: Three rifle platoons conduct four iterations of the platoon raid at Camp Ripley. Each platoon conducts a day/night blank iteration and a day/night live-fire iteration. This rotation will encompass four days of training.		
3. COLLECTIVE TASKS: This training supports the following collective tasks:		
TASK	REFERENCE	PAGE
Prepare for combat	ARTEP 7-8-MTP	5-158
Occupy assembly area	ARTEP 7-8-MTP	5-46
Move tactically	ARTEP 7-8-MTP	5-49
Occupy objective rally point	ARTEP 7-8-MTP	5-66
Reconnoiter area	ARTEP 7-8-MTP	5-109
Perform raid	ARTEP 7-8-MTP	5-23
Employ fire support	ARTEP 7-8-MTP	5-100
Consolidate and reorganize	ARTEP 7-8-MTP	5-167
4. INDIVIDUAL TASKS: See ARTEP 7-8-MTP for a listing of the individual tasks that support the collective tasks.		

Figure 6-1. Example platoon training plan.

5. TRAINING SCHEDULE/ROTATION:

A CO will move from billets to vicinity UB 895245 where the company CP will be set up. All rotations will be staged from this area. The time schedule for the rotations will be determined.

DAY 1 (23 SEP)

1st PLT Day BFX
 2d PLT Day BFX
 1st PLT Night BFX
 3d PLT Collective Training

DAY 2 (24 SEP)

3d PLT Day BFX
 2d PLT Night BFX
 3d PLT Night BFX
 1st PLT Collective Training

DAY 3 (25 SEP)

1st PLT Day LFX
 3d PLT Day LFX
 1st PLT Night LFX
 2d PLT Collective Training

DAY 4 (26 SEP)

2d PLT Day LFX
 3d PLT Night LFX
 2d PLT Night LFX
 1st PLT Collective Training

Upon completion of training on 26 September, the company will infiltrate by platoon from UB 895245 to a company linkup vicinity UP 923210 to field plan the company MTC.

6. SERVICE SUPPORT:

- a. Rations cycle for training period will be A-C-A.
- b. Ammunition—TBD.
- c. Miles—N/A.
- d. AARs: CO, XO, 1SG.
- e. Transportation: TBD.

7. SAFETY PLAN: All leaders will be safeties during this mission. All weapons must be on safe except when firing.

Firing point location: UB 90182572

Left limit: 5670 mils/319 degrees (magnetic)

Right limit: 0490 mils/27.5 degrees (magnetic)

Platoon leaders will check the safety fan with LT Rock before and upon completion of day BFX.

8. LEADERS' TEWT: 22 TBD SEPT 91.

Figure 6-1. Example platoon training plan (continued).

6-5. SETUP

Preparing for the platoon LFX is similar to that of the squad.

a. A recommended maneuver box for the platoon would be one that consists of a 2- by 5-kilometer box. The platoon needs to employ its different types of weapon systems within the planned SDZs, with regard to azimuth and distance. These should be incorporated into the TEWT and rehearsal, which is conducted before execution of the LFX.

b. Leaders must adjust scenarios based on range restrictions, terrain, and training objectives. At platoon level, all possible nonorganic weapon systems should be used. The maneuver box area needed for different type missions varies. The unit obtains a clear picture of this as it begins planning its SDZs for all weapons.

c. Doctrine must support the target array. Leaders should use a scenario to replicate threat dispositions. When planning the scenario, leaders should consider the following:

(1) The enemy target must engage the unit at the proper distance.

(2) The enemy target must be located in proper relation to the rest of the enemy positions.

(3) The enemy target must be located in a realistic area utilizing terrain (not in an open field but behind a tree in a fighting position). For example, on a movement to contact, an observation post could be placed between 200 to 500 meters away from where the unit will be engaged, 200 meters in front of the enemy squad it supports (which is part of a notional platoon), in hasty fighting positions.

6-6. EXECUTION OF THE LIVE-FIRE EXERCISE

The execution of a platoon maneuver box LFX is much like that of the squad. However, when conducting a platoon exercise, the leader should rotate the squads through all phases of training so all soldiers participate and understand what is required to accomplish each mission.

a. **Safety briefing.** A safety briefing should always be conducted before the LFX. (A sample briefing is included in Appendix A.)

b. **Risk assessment.** This is a leader's responsibility. The unit must be assessed to determine if conditions exist that will make the LFX hazardous (lack of sleep, lack of experience with a complex and or dangerous task, and so on). (A sample risk assessment can be reviewed in Appendix A.)

c. **Leader Participation.** In a platoon exercise, the company commander can provide input and receive reports through radio communications with his platoon leaders. The commander can direct action as a teaching point or just allow the platoon to maintain momentum. In addition, the commander can strengthen his working relationship with his squad and platoon leaders, and gain first-hand knowledge of their experience and capabilities.

d. **Combat Support/Combat Service Support Participation.** Aidmen, FISTs, and engineer personnel should participate in the LFX performing the same duties they would in war. This provides training and tells them what the unit expects of them in the field.

6-7. OBSERVERS-CONTROLLERS

The OC assists the unit in contributing to the realism of force-on-force and LFXs by coordinating indirect fires, assessing casualties, controlling targetry, stopping unsafe acts, and assisting in the conduct of AARs. (See Chapter 5 and Appendix H.)

6-8. ASSESSMENT

Assessment is a critical part of the LFX. It is based on MTP standards, FMs 7-7 and 7-8, and marksmanship data. An assessment is not a test. It is a self-evaluation (with OC and unit input) that helps the unit focus on areas for self-improvement. The assessment is facilitated through the use of AARs. Leaders and OCs are not the only speakers in a unit AAR. All soldiers should note problems and successes, and discuss them in the AAR. (See Chapter 5 and Appendix J.)

6-9. AFTER-ACTION REVIEW

The AAR is one of the most important aspects of training. It allows a unit's strengths and weaknesses to be discovered and discussed so training goals can be set for the future. The AAR should be conducted at the lowest levels so all soldiers have input and will come to recognize their unit's strengths and weaknesses—not just be told what they are by the chain of command. In this manner, training will have legitimacy, hence the support of all soldiers. The success of an AAR depends mostly on the conductor. This individual should be thoroughly trained and rehearsed in giving AARs, and should be an expert in unit tactics. The AAR should not only concentrate on the separate tasks and subtasks of the mission, but also on each battlefield operating system (BOS) and the battle as a whole. (More information can be found in the appropriate MTP.)

6-10. PLATOON MISSION

This paragraph focuses on the integration of three well-trained squads into a combat proficient platoon. It presents an exercise scenario based on ARTEP MTP missions/standards. The commander should change, add, or delete missions based on his unit's METL and METT-T. Before the LFX, training following the crawl, walk, run concept will be conducted (dry fires and MILES exercises).

MISSION: 1st PLT, B CO, 2/22 IN conducts a movement to contact NLT 140630 Jul 92 to reestablish contact with enemy forces along Axis Green.

a. Range and Targetry.

(1) Threat and friendly targets should be constructed to simulate three-dimensional life-size targets. Targets are activated by an OC using an electronic transmitter. When a target is hit, a mechanism is activated causing the target to drop to the ground.

(2) Enemy targetry is placed according to threat doctrine and engages the friendly forces at the appropriate range with respect to the capabilities of the enemy weapons and terrain. Targets are clothed in OPFOR uniforms.

(3) Friendly targetry should be placed along boundary lines, contact points, and so on. If they are engaged, range safety fans must not be violated.

(4) Pneumatic firing devices with MILES transmitters attached to a vehicle windshield motor creates a fan of return fire. This "fire" is supplemented by the controllers for indirect enemy fires and unsafe acts. All targetry equipment is hardened as much as possible to protect it from weapon systems employed in the LFX.

(5) For a platoon-size LFX, the maneuver box should be about 3,000 to 5,000 meters long and 1,000 meters wide. This does not include an assembly area or the SDZs that merge into the impact area.

b. Scenario.

(1) **General situation.** The battalion has seized key terrain within its area of operations. Contact with enemy elements has been broken. Intelligence reports indicate the enemy is retreating and will defend in squad size elements to slow friendly forces. The enemy is believed to have the capability to counterattack in regimental strength within the next 36 hours.

(2) **Special situation.** The company is in an assembly area when ordered to conduct a movement to contact, cross the LD, and orient on three separate march objectives. The company commander's FRAGO specifies that enemy squad or larger formations will not be bypassed unless ordered.

(3) **Phase I.** The platoon, as part of the company movement to contact, comes under sniper fire. The platoon executes the react to contact battle drill and develops the situation. The platoon continues the movement to contact.

(4) **Phase II.** The platoon continues the mission and comes under indirect fire. It executes the react to indirect fire battle drill.

(5) **Phase III.** The platoon then comes under direct fire from an OPFOR OP with machine gun. The platoon executes the react to contact battle drill, develops the situation, and neutralizes the position. The

platoon consolidates and reorganizes, and continues the mission. (The platoon may continue the mission as long as necessary to attain the overall training objective.)

(6) **Phase IV.** The platoon is engaged by an enemy squad. The platoon's lead squad executes the react to conduct battle drill. It quickly establishes a base of fire. The platoon leader determines whether to maneuver one or two squads against the enemy. In rapid succession, the platoon: employs fire support, supports assault by fire, breaches obstacles, clears trench lines and or knocks out bunkers, consolidates and reorganizes, and on order, defends the position. If the platoon leader decides he can't take the position, he contacts the commander for further instructions (the CO may maneuver another platoon against the position) and or he conducts the break contact battle drill. (Operations may continue with other tasks the commander would like to train, such as establish hasty defense.)

(7) **Phase V.** The unit conducts an AAR IAW the tactical situation and prepares for the next mission.

c. Weapon Accommodation.

(1) Weapons systems in the platoon LFX now include M60 machine guns, Dragons, fragmentation grenades, and AT4s. In addition, mortars, artillery, and bangalore torpedoes could be integrated into a platoon exercise, based on the mission.

(2) The SDZs are based on the largest caliber ballistic weapon/munitions to be used. They need to be plotted from the most probable axes of march that the platoon leaders might select. These axes of march can be influenced through operations orders that define boundaries, restrictive fire areas, and so on, and control which target array to activate.

(3) Using the extreme engagement limits, the maximum distance of fire is plotted to the left, right, and forward of the participating units line of fire. The possibility of an injury caused by friendly fire is increased on this range. Personnel must follow the safety precautions presented in the safety briefing.

6-11. LOGISTIC SUPPORT

Logistic support covers the amount and type of equipment and ammunition needed for each phase of live-fire training at platoon level—whether crawl (dry fire/walk-through), walk (rehearsal with MILES), or run (live fire) (Tables 6-1 through 6-6). The ammunition requirements are based on DA PAM 350-38 using a maneuver box with no weapon caliber restrictions. (Appendix F provides a validated sample of ammunition used at the JRTC for platoon movement to contact, ambush, and deliberate attack.) The equipment requirements are based on various

training documents. These requirements can be adjusted to the unit's training objectives based on METL and METT-T.

a. **MILES Rehearsal Ammunition Requirements.** Most blank ammunition for the rehearsal is drawn from the unit's squad, platoon, or company FTX allocations. Adding all blank allocations listed in this manual (from buddy team to platoon) equals that ammunition allocated for one FTX. Depending on how much the unit forecasts for other uses, this amount can be adjusted as desired.

b. **Live-Fire Ammunition Requirements.** The ammunition type and quantity comes from DA PAM 350-38. The quantity of some ammunition can be increased by integrating allocations for other training events—as long as those training goals are addressed in the LFX. In some cases, live ammunition can be used instead of simulators. (For example, even though five 9-mm rounds for each platoon are allocated for the AT4 in the LFX, a yearly allocation of one live round for each firer [four for each rifle squad] exists. These live rounds can be integrated into the LFX.) Pyrotechnics are also addressed in DA PAM 350-38.

WARNING
The M203 fires M 16A1 ammunition. Using M 16A2 ammunition may cause damage to the M203.

LIN/NSN	NOMENCLATURE	EQUIPMENT-STUDENT RATIO
N/A	CONTROLLER	1/SQUAD
1265-01-075-4893	MILES, MAN-WORN LASER DETECTOR	1/1
1265-01-079-5264	MILES, M16 LASER TRANSMITTER	1/1
1265-01-092-0891	CONTROLLER GUN	1/CONTROLLER
6135-01-063-1978	BATTERY, BA 3090	3/1
6135-01-063-1978	BATTERY, BA 3090	1/CONTROLLER GUN
6135-00-643-1310	BATTERY, NONRECHARGEABLE 1991	3/SAAF
11835282 9353020	SMALL-ARMS ALIGNMENT (SAAF) OR SMALL-ARMS ALIGNMENT FIXTURE	4/PLATOON

Table 6-1. Dry-fire training aids and equipment (crawl).

DODAC	WEAPON	NOMENCLATURE	EQUIPMENT-STUDENT RATIO
1330-G950	—	HG, RED SMOKE M18	2/PLATOON
NOTE: Some blank ammunition may be needed for demonstrations.			

Table 5-2. Dry-fire ammunition requirements (crawl).

LIN/NSN	NOMENCLATURE	EQUIPMENT-STUDENT RATIO
N/A	CONTROLLER	1/SQUAD
1265-01-075-4893	MILES, MAN-WORN LASER DETECTOR	1/1
1265-01-079-5264	MILES, M16 LASER TRANSMITTER	1/1
1265-01-092-0891	CONTROLLER GUN	1/CONTROLLER
6135-01-063-1978	BATTERY, BA 3090	3/1
6135-01-063-1978	BATTERY, BA 3090	1/CONTROLLER GUN
6135-00-643-1310	BATTERY, NONRECHARGEABLE 1991	3/SAAF
11835282 9353020	SMALL-ARMS ALIGNMENT (SAAF) OR SMALL-ARMS ALIGNMENT FIXTURE	4/PLATOON

Table 6-3. MILES rehearsal training aids and equipment (walk).

DODAC	WEAPON	NOMENCLATURE	EQUIPMENT-STUDENT RATIO
1305-A080	M16	CTG, 5.56-mm, BLANK, M200	20/1
1305-A075	M249	CTG, 5.56-mm, BLANK, M200 LKND W/M27	70/1
1305-A111	M60	CTG, 7.62-mm BLANK M82 LKND W/M13	800/1
1330-G811		BODY F/HAND GRENADE	4/SQUAD
1330-G878	M228	FUZE, GRENADE, PRACTICE	4/SQUAD
1310-B519	M203	40-mm, PRACTICE, M385 (TP-T)	2/1
	M47	DRAGON (INERT)	2/PLATOON
1345-K150	M18A1	MINE, APERS M81 INERT W/ACC	1/TEAM
1330-G950		HG, RED SMOKE M18	2/PLATOON
RESOURCE DRAWN FROM STRAC: A080 Squad, PLT, CO FTX/STX, Table 5-30, page 89. A075 Squad, PLT, CO FTX/STX, Table 5-28, page 88. A111 Squad, PLT, CO FTX/STX Table 5-24, page 86. G878 Squad, PLT, LFX, 8/Squad, 8 Events, Table 5-41, page 92. B519 Squad, PLT, LFX, 24 TP/WPN, 8 Events, Table 5-34, page 90.			

Table 6-4. MILES rehearsal ammunition requirements (walk).

LIN/NSN	NOMENCLATURE	EQUIPMENT-STUDENT RATIO
N/A	CONTROLLER	1/SQUAD
1265-01-075-4893	MILES, MAN-WORN LASER DETECTOR	1/1
1265-01-079-5264	MILES, M16 LASER TRANSMITTER	1/1
1265-01-092-0891	CONTROLLER GUN	1/CONTROLLER
6135-01-063-1978	BATTERY, BA 3090	3/1
6135-01-063-1978	BATTERY, BA 3090	1/CONTROLLER GUN
6135-00-643-1310	BATTERY, NONRECHARGEABLE 1991	3/SAAF
11835282 9353020	SMALL-ARMS ALIGNMENT (SAAF) OR SMALL-ARMS ALIGNMENT FIXTURE	4/PLATOON

Table 6-5. Live-fire training aids and equipment (run).

DODAC	WEAPON	NOMENCLATURE	EQUIPMENT-STUDENT RATIO
1305-A059	M16A2	CTG, 5.56-mm, BALL, M855 10/CLIP	130/1
1305-A063	M16A2	CTG, 5.56-mm TRCR M856 CARTON PACK	20/1
1305-A064	M249	CTG, 5.56-mm, 4 BALL M855/1 TRACER M856 LKD	500/1
1305-A131	M60	CTG, 7.62-mm 4 BALL/1 TRACER LINKED W/M13	500/1
1310-B519	M203	40-mm, PRACTICE, M781 (TP)	24/1
1310-B535	M203	40-mm, WHITE STAT PARA ILLUM, M58A1	6/1
1330-G881	M67	GRENADE, HAND FRAG M67	1/SOLDIER
1330-	M228	GRENADE, HAND FRAG M228	8/SQUAD
1340-H708	M72A2	RKT, 35-mm SUBCAL, M73 (PRAC)	4/SQUAD
1340-H557	M72A2	RKT, 66-mm HEAT M72 (LAW)	*
1315-C995	M136	LAUNCHER AND CTG, 84-mm M136 AT4	4/SQUAD
1305-A358	M136	9-mm, PRACTICE, M939 F/AT4	4/SQUAD
1427-PL22	M47	GUIDED MISSILE AND LAUNCHER, SURFACE ATK, PRACTICE, M223 (DRAGON)	*
	M47	DRAGON (INERT)	*
1427-PL23	M47	GUIDED MISSILE AND LAUNCHER, SURFACE ATTACK, M222 (LIVE RD)	1/SYSTEM
1370-L367	M47	SIMULATOR, ATWESS M22	2/GUNNER
1345-K143	M18A1	MINE, APERS M18A1, (INERT) W/ACC	1/SQUAD
1375-M028	—	BANGALOR TORPEDO M1A2	*
1330-G950	—	HG, RED SMOKE M18	*

Table 6-6. Live-fire ammunition requirements (run).

DODAC	WEAPON	NOMENCLATURE	EQUIPMENT-STUDENT RATIO
1330-G930	—	HG, HC AN-18	*
1330-G940	—	HG, GREEN SMOKE M18	*
1330-G955	—	HG, VIOLET SMOKE	*
1310-B643	M224	CTG,60-mm HE M888	48/1
1310-B627	M224	CTG, 60-mm ILLUM M83A3	8/1
1310-B630	M224	CTG, 60-mm WP M302A1	4/1
1315-C236	M26A1	CTG, 81-mm HE M374 SERIES W/O FUZE	46/1
1390-N334	M26A1	FUZE PD M567 (81-mm)	*
1315-C226	M26A1	CTG,81-mm ILLUM M301 SERIES	6/1
1315-C276	M26A1	CTG, 81-mm WP M375 SERIES W/PD FUZE	7/1
1375-M023	C4	CHG, DEMO BLOCK 1 1/4C4 M112	*
1375-M670	—	FUZE, BLASTING, TIME M700	*
1375-M456	—	CORD, DETONATING TYPE-I, CLASS E	*
1375-M131	—	BLASTING CAP, NON-ELEC M7	*
1375-M766	—	IGNITER, TIME BLASTING FUSE: M60	*
<p>Resource drawn from STRAC (not IAW SQD/PLT live-fire):</p> <p>G881 Live hand grenade throw, 1 per year, Table 5-41, page 92. C995 Live rocket per year (AT4), 1 per firer, Table 5-14, page 82. PL23 Live rocket per year, (Dragon), 1 per firer, Table 5-12, page 81. B643 CREW/SEC TNG (60-MM), once per year, Table 5-18, page 83. B627 CREW/SEC TNG (60-MM), once per year, Table 5-18, page 83. B630 CREW/SEC TNG (60-MM), once per year, Table 5-18, page 83. B236 CREW/SEC TNG (81-MM), once per year, Table 5-19, page 84. B226 CREW/SEC TNG (81-MM), once per year, Table 5-19, page 84. B276 CREW/SEC TNG (81-MM), once per year, Table 5-19, page 84.</p> <p>* Resourced in DA Pam 350-38, Chapter 8, Pyrotechnics.</p>			

**Table 6-6. Live-fire ammunition requirements.
(run) (continued).**

APPENDIX A

SAFETY

This appendix provides example recommendations, weapons training safety checklists, briefings, and incident report formats for use on a live-fire range. These are meant to be used as a guide and must be modified to fit Army and installation safety regulations.

In order to train to combat readiness, the chain of command must act as LFX safety officers. As in combat, the chain of command may have to halt the move if certain safety concepts are violated. Once the problem is resolved, the unit can continue the operation. The unit's command net should also be the safety communications net.

A-1. RISK ASSESSMENT

Risk assessment is the process of identifying the risks associated with an operation and weighing those risks against the overall training value to be gained. Leaders must assess the risk of all training as a part of pre-execution checks. Proper risk management makes safety a part of the mission. It is a way of getting the mission done with the least possible risk to soldiers and equipment.

a. The simplest method of identifying risks is the use of a risk matrix (Figure A-1, page A-2). The risk matrix gives the leader an overview of the inherent risks of the operation. Different missions will involve different elements that can affect mission safety. Planning, supervision, soldier endurance, soldier selection, weather, mission complexity, and equipment have historically proven to be central causes of accidents. Using matrixes to assign a numerical value to each of these elements is one way of quickly determining the risk associated with a particular mission.

RISK ASSESSMENT WORKSHEET

1. MISSION ANALYSIS: LEF
 2. HAZARD ASSESSMENT:
 HAZARDS CERTAIN TO ARISE:
 A. FIRES C. FLYING AIRCRAFT
 B. MORTARS FIRING
 HAZARDS THAT MAY ARISE:
 A. FOG B. _____
 3. RISK ASSESSMENT: (circle one)

COMPLEXITY			
OPERATIONAL AREA			
OPERATION LENGTH	IMPROVED	TACTICAL	UNKNOWN
48 HRS	3	4	5
24 HRS	2	3	4
08 HRS	(1)	2	3

SOLDIER ENDURANCE			
LENGTH OF REST (LAST 24 HRS)			
QUALITY OF REST	8 HRS	4 to 8 HRS	Less than 8 HRS
tactical	3	4	5
training	2	3	4
garrison	1	(2)	3

PLANNING			
PREPARATION			
GUIDANCE	IN-DEPTH	ADEQ	MINIMAL
vague	3	4	5
implied	2	3	4
specific	(1)	2	3

WEATHER			
VISIBILITY/MOISTURE			
TEMP F	CLEAR/DRY	OVERCAST/ DRIZZLE	FOG/RAIN SNOW/ICE
0-31	3	4	5
32-59	2	(3)	4
60+	1	2	3

SUPERVISION			
MISSION			
COMMAND CONTROL	SPT NON TACT	DAY TACT	NIGHT TACT
OPCON	3	4	5
attached	2	3	4
organic	1	(2)	3

SOLDIER SELECTION			
SOLDIER EXPERIENCE			
TASK	HIGHLY QUALIFIED	MOS QUALIFIED	OJT
complex	(3)	4	5
routine	2	3	4
simple	1	2	3

EQUIPMENT				
MAINTENANCE STATUS				
EQUIP AGE	HIGH C-1	C-2	C-3	NMC C-4
OLD	3	4	5	5
AVG	2	(3)	4	5
NEW	1	2	3	5

TOTAL RISK VALUE: 15

RISK	POINT	DECISION LEVEL
LOW	0 - 12	PLT LDR
CAUTION	13 - 23	CO CDR
HIGH	24+	BN CDR

Figure A-1. Example risk assessment worksheet.

b. Risk may be assessed by measuring the various risks present in the operation, combining their values, and then making a judgment as to the safety precautions that are appropriate in the given situation. By arriving at a total risk value, the leader can determine if the proposed method of conducting a mission falls within acceptable risk parameters. He can then change one or all areas of the operation to reduce the total risk value. As a minimum, he will know whether or not his soldiers are functioning in a high-risk environment.

c. In addition to the general perspective, leaders need to detect specific hazardous situations; for example, dangerous artillery support plans, specific hazards of a river crossing. The hazard assessment provides this detail. Hazard assessment is the initial examination of an operation's hazards and their implications. It is normally based on the mission analysis and takes place before the details of an operation have been completely defined. Hazard assessment has one objective. It defines at the earliest possible stage what hazards can be expected in each of the major operational phases. Hazards can be dealt with if assessed early when the operation is still being planned. This assures that hazard controls can be developed and implemented as the operation evolves.

d. The use of risk matrices and hazard analyses define the kinds and significance of hazards faced in an operation. The task then is to reduce the risk without significant adverse impact on the operation.

e. The countermeasure option checklist in Figure A-2 can be directly applied to the development of risk-reduction options. It can be used to develop a full array of possibilities and reject those that are clearly impractical. The product of the risk-reduction phase should be a list of options that are practical, although not necessarily desirable, for the particular operation.

f. The basic assessment elements in Figure A-2 can be adapted to fit organizational needs. Additional matrix charts that blend in special considerations can be developed.

<input type="checkbox"/> Eliminate the hazard or substitute a less hazardous alternative.
<input type="checkbox"/> Control the hazard by reducing the magnitude of the hazard or providing containment or barriers.
<input type="checkbox"/> Change operational procedures to minimize risk exposure consistent with mission needs.
<input type="checkbox"/> Educate by training personnel in hazard recognition and avoidance.
<input type="checkbox"/> Motivate personnel to use effective hazard avoidance actions.

Figure A-2. Countermeasure option checklist.

g. The key to risk management is not accepting preventable risks. Preventable risks are those that can be reduced or eliminated using available resources and technology without disrupting the mission.

h. Changes in training progress and conditions must be continually assessed during training and appropriate corrective actions taken as these conditions affect the level of risk.

A-2. SAFETY RECOMMENDATIONS

The following are some safety recommendations for use on live-fire ranges. They are not for use on all ranges, but must be considered when planning an LFX. Remember, even though safety is important, the primary focus is the establishment of a well-organized, realistic LFX.

a. **Protective Jackets/Vests, Eye Protection.** Using protective jackets/vests and ballistic goggles (if available) on live-fire ranges greatly enhances safety. They may be worn in time of war, so soldiers should get used to fighting with them on. Ear plugs may be worn on special occasions, but the commander should consider this in his risk assessment—not hearing a command could get someone killed. The decision to wear such protective equipment is based on the commander's assessment of METT-T, his risk analysis, and the weather. Protective jackets provide extra protection against small-arms weapons and fragmentation.

b. **MILES Harnesses.** MILES harnesses can be worn by all soldiers to enhance both safety and realism. Safety personnel can shoot controller guns at soldiers who are either using improper individual movement techniques or who are safety hazards.

c. **Safety Signals.** Safety signals must be planned so that they can be seen by everyone on the range. While a red star cluster can be seen on a clear night, it probably will not be seen when fired during the day toward the sun. A minimum of one back-up signal and continuous communications between all safety personnel must be planned. The command frequency (the frequency that the live-fire unit is using) is used to signal cease fire.

d. **Night Fire.** Night firing creates additional safety considerations because of the reduced visibility. At a minimum, all safety personnel, leaders, and machine gunners must have night vision goggles or sights (NVDs). Compasses should be preset on their luminous points. Commanders should consider marking firing limits based on terrain, visibility, and the level of training his unit has achieved.

e. **Smoke.** The use of smoke can add realism to any range but must be employed carefully. Before beginning the LFX, a rehearsal is conducted using smoke to determine what effect it has on visibility. The support position must be able to observe the movement of the assault force. Too much smoke can create a safety hazard that could overcome the benefits of its use.

f. **Briefbacks.** Conducting thorough briefbacks allows leaders to avoid hazards caused by poor planning and communications. Briefbacks should occur frequently during planning and execution of the LFX.

A-3. WEAPONS AND PYROTECHNICS PROFICIENCY TRAINING

Training should be conducted on all weapons and pyrotechnics that will be used on the live-fire mission. All individual gunners who will take part in LFXs must have fired and passed a qualification course for the crew-served weapon assigned to them. All personnel who will fire a weapon in the exercise must have fired, as a minimum, a familiarization course with that weapon. Training should include demolitions, grenades, Claymore mine simulators, and any other devices that could also be used on the range.

a. Support positions for raids should be on terrain that has cover to the flank (if possible) and does not allow M60 machine gun fire to go in the direction of the assault line. If such a position is not available, a berm can be constructed and camouflaged.

b. Hand-held flares and star clusters that are used for signaling or illuminating must be handled with extreme caution. Instruction should be given to those members of the unit who will use these pyrotechnics.

c. Individual movement techniques (IMT) training should be given to all LFX participants. Weapons proficiency training should be incorporated with emphasis on reducing stoppages (immediate action); magazine exchange (M16A1/A2); loading and firing the M203, M60, and M249 machine gun; and subcaliber rounds for the antitank weapons. Fire and movement rehearsal should be extensive during training with both officers and NCOs emphasizing muzzle control of weapons at all times. Continual reminders to put weapons on safe before moving and to note the whereabouts of other individuals in the area are aspects of safety critical for both live-fire operations and combat.

(1) The movement of buddy teams, fire teams, and squads should be trained progressively and in detail with emphasis on control of elements. Training by platoon and squad leaders in arm-and-hand signals, visual signals (such as pyrotechnics), and whistles is critical. Leaders find it extremely difficult to communicate orally due to excessive levels of noise during LFXs and force-on-force operations. Leaders at all levels *must* retain control of their elements at all times throughout the conduct of the live-fire mission.

(2) The fire-team leader is the foundation of fire and movement. Based on the premise that the members of the fire team follow the fire-team leader and "do as he does," this leader's actions are critical to the success and safety of live-fire missions. Assigning numbers to team members can be used as a fire control measure. For example, the team

leader is one, the automatic rifleman is two, the grenadier is three, and the rifleman is four. The team leader can then simply refer to the team member's number if he wishes him to initiate a 3- to 5-second rush. All soldiers should stay alert to the actions of fellow team members and squads to their left and right. Anticipating actions on the battlefield gives units the ability to remain flexible.

A-4. WEAPON-HANDLING PROCEDURES

The following guideline describes procedures and requirements for handling all organic and special operation weapons. These procedures are based on lessons learned from the Persian Gulf war and are designed to prevent safety-related accidents and fratricide. They are intended for use in both training and combat and apply to all assigned weapons of a unit. In all cases, strict supervision is critical for the safe handling of weapons. For training purposes, the chain of command will include range cadre.

a. Procedures. The procedures for weapons handling may vary based on METT-T. The following procedures are strongly recommended:

(1) Upon issue, all weapons are immediately cleared and placed on "safe" IAW appropriate Soldier's Manual or Operator's Manual.

(2) Weapons always remain on "safe." The only exceptions to this policy are—

(a) When weapons are stored in an arms room.

(b) Immediately before target engagement.

(c) When directed by the chain of command.

(3) Weapons should be handled as if they are loaded at all times. Horseplay with weapons resulted in fratricide incidents during the Persian Gulf War. Weapons are never pointed at an individual unless a life-threatening situation justifies the use of deadly force. Soldiers must always be aware of the muzzle direction of their weapon and of the weapons status; for example, loaded/safe.

(4) Magazines/belts are inserted in weapons upon the direction of the chain of command.

(5) AR 385-63 should be reviewed by the unit's leaders before range firing/qualification.

b. Load and Chamber Procedures (Lock and Load). The chain of command determines when to load the weapon and chamber a round in reference to mission, enemy, terrain, troops, and time available in a combat environment. Generally, weapons remain on "safe" until ready to fire.

c. Administrative Procedures. Administrative procedures include weapons clearing, grounding/stacking of weapons, and aircraft and vehicle movement.

(1) **Administrative weapons clearing.** Administrative weapons clearing is performed following the completion of the tactical phase of all live fires and range qualifications, or upon reentry of a secure area in combat. Magazines or belts are removed from all weapons. The chain of command inspects all chambers visually, using red filtered light if at night, and verifies that each weapon and magazine is clear of ammunition. Weapons should also be rodded. Magazines are not reinserted into weapons. During training, ammunition must be turned in and accounted for with brass and ammunition checks completed.

(2) **Grounding/stacking of weapons.** If stacked, procedures outlined in FM 22-5 are used. If grounded with equipment, all weapons are placed on "safe" and arranged off the ground with the open chamber visible, if applicable. Biped-mounted weapons are grounded on bipeds with all muzzles facing downrange and away from nearby soldiers.

(3) **Aircraft and vehicle movement.** Weapons should always be cleared and on "safe" when conducting movement in aircraft and vehicles IAW SOP. Weapon muzzles must be pointing downward when traveling on aircraft. Weapons are locked and loaded only after exiting the aircraft or vehicle, or upon command of the leader.

NOTE: Particular care must be given to correct handling of the pistol, especially the M9 with its double action (fire from the hammer down) feature. The removal of the M9 pistol from the holster can accidentally move the safety lever to "fire" permitting immediate double action mode of fire. Pistols should not have a round chambered unless a specific threat warrants it.

A-5. EXAMPLE SAFETY CHECKLISTS

Safety checklists should be used before conducting LFXs. Figures A-3 through A-5 show examples of different safety checklists. The safety checklist for soldiers should be the same that would be used in combat and should be adapted to METT-T.

___ TAKE ALL ORDERS FROM LEADERS AS IN COMBAT.
___ KNOW THE LOCATION OF LEFT AND RIGHT LIMITS.
___ KNOW THE LAYOUT OF THE MANEUVER BOX.
___ KEEP WEAPON ORIENTED WITHIN ASSIGNED SECTOR OF FIRE.
___ KNOW HOW TO SIGNAL/CALL CEASE FIRE IF AN UNSAFE ACT IS OBSERVED, BUT NOT CORRECTED.
___ IDENTIFY ENEMY (DESCRIBE TARGETS).

Table A-3. Example safety checklist for soldiers.

- PLACE WEAPON ON SAFE BEFORE MOVING OR WHEN NOT ENGAGING.
- MOVE WITH WEAPON ON SAFE AND POINTED AWAY FROM FRIENDLY SOLDIERS.
- LOCK AND LOAD ON ORDER OR IAW SOP.
- DO NOT CROSS IN FRONT OF ANOTHER SOLDIER.
- KNOW SPECIFIC SAFETY REQUIREMENTS INVOLVING PYROTECHNICS/EXPLOSIVES.
- ENSURE WEAPON BARREL DOES NOT GET JAMMED WITH DIRT WHEN DOING INDIVIDUAL MOVEMENT TECHNIQUES.
- USE THE APPROPRIATE CLEARING PROCEDURES ON WEAPON MALFUNCTIONS.
- NOTIFY THE LEADER IF A WEAPON MALFUNCTION CANNOT BE CLEARED.
- WEAR EARPLUGS (when not a hazard to communication).
- KNOW COMMUNICATIONS—ARM-AND-HAND, VOICE, RADIO SIGNALS—WITHIN MANEUVER UNIT.
- KNOW WEATHER FORECAST.
- KNOW PARTICULAR GEOGRAPHICAL CONCERNS (FOR EXAMPLE, THUNDERSTORMS, SNAKES).
- USE RED SMOKE OR RED STAR CLUSTER TO SIGNAL EMERGENCY CEASE FIRE - ECHO THE CEASE FIRE ORDER.
- DO NOT GRAB THE HOT BARREL OF A MACHINE GUN OR RIFLE.
- WHEN CEASE FIRE IS GIVEN, STOP FIRING, ECHO THE COMMAND, PLACE WEAPON SELECTOR SWITCH ON SAFE.
- REMOVE THE MAGAZINE AND CLEAR THE WEAPON ON COMMAND.
- RETURN ALL UNEXPENDED AMMUNITION TO ISSUE POINT.
- WEAR HELMETS, WITH CHIN STRAPS FASTENED, DURING THE EXERCISE.
- ENSURE WEAPONS ARE CLEARED BY CHAIN OF COMMAND.

Figure A-3. Example safety checklist for soldiers (continued).

KNOW THE LAYOUT OF THE MANEUVER BOX AND ACCESS ROAD NETWORK.

KNOW THE LOCATION OF THE OIC (COMMANDER).

KNOW WHERE VISITORS ARE TO REPORT.

KNOW COMMUNICATION DETAILS (FREQUENCIES, CALL SIGNS, SIGNALS, MEDEVAC).

KNOW THE LOCATION OF OTHER ROAD GUARD POSTS.

KNOW THE LOCATION OF THE SERGEANT OF THE GUARD.

KNOW THE LOCATION OF AUTHORIZED PARKING.

WEAR ROAD GUARD VESTS.

MAKE COMMUNICATION CHECK BEFORE BEING POSTED.

CARRY EXTRA RADIO BATTERY (ESPECIALLY IN COLD WEATHER)

KNOW THE ACTIONS TO TAKE IF COMMUNICATION FAILS.

CARRY FOOD, IF NECESSARY.

CARRY FULL CANTEENS.

IN COLD WEATHER, ROTATE GUARDS INTO A WARMING TENT.

KNOW THE ACTIONS TO TAKE IF A VEHICLE IGNORES OR DEFIES THE ROAD GUARD AND ENTERS A RESTRICTED AREA.

Figure A-4. Example safety checklist for road guards.

KNOW THE LAYOUT OF THE RANGE AND ACCESS ROAD NETWORK.

HAVE A STRIP MAP TO THE HOSPITAL.

KNOW THE LOCATION OF NEAREST MEDEVAC PICK-UP POINT.

HAVE AIDMAN OR DRIVER STAY WITH THE EVACUATION VEHICLE.

HAVE ONE AIDMAN WITH FULL MEDICAL KIT BAG FOLLOW THE OIC.

HAVE THE EVACUATION VEHICLE PERSONNEL MONITOR THE RANGE SAFETY NET.

KNOW THE COMMUNICATION DETAILS (FREQUENCIES, CALL SIGNS, MEDEVAC).

Figure A-5. Example safety checklist for aidmen.

___ USE VS-17 PANEL, STROBE LIGHTS, SMOKE GRENADES TO MARK CASUALTY PICK-UP POINT.

___ KNOW THE WEATHER FORECAST.

___ KNOW THE PARTICULAR GEOGRAPHICAL CONCERNS (FOR EXAMPLE, THUNDERSTORMS, SNAKES).

___ USE EARPLUGS IF NEAR THE FIRING LANE.

Figure A-5. Example safety checklist for aidmen (continued).

A-6. EXAMPLE SAFETY BRIEFING

Before any exercise, all soldiers should receive a safety briefing. This briefing is based on the type of munitions to be used and on METT-T. Figures A-6 through A-8 provide general guidelines for constructing a unit safety briefing.

(1) DO NOT FIRE WEAPONS DIRECTLY AT OTHER PERSONNEL WHEN WITHIN 15 FEET OF THEM.

(2) WEAR HELMETS AND FASTEN LBE.

(3) ENSURE BLANK ADAPTERS ARE ATTACHED.

(4) TURN IN BLANK AMMUNITION BEFORE BEING ISSUED LIVE AMMUNITION.

(5) KNOW THE SPECIAL INSTRUCTIONS FOR PYROTECHNICS.

Figure A-6. Example safety briefing for blank fire.

(1) WEAR HELMET, WITH CHIN STRAP FASTENED, AT ALL TIMES.

(2) WEAR EARPLUGS.

3) PLACE THE SELECTOR SWITCH OF THE WEAPONS ON "FIRE" ONLY WHEN FIRING WEAPON; OTHERWISE, THE SELECTOR SWITCH IS PLACED ON "SAFE."

(4) PERFORM IMMEDIATE ACTION TO REDUCE STOPPAGES.

Figure A-7. Example safety briefing for live fire.

- (5) DO NOT POINT WEAPON AT ANOTHER SOLDIER AT ANY TIME. ONCE THE WEAPON HAS BEEN LOADED, KEEP IT TOWARD YOUR ASSIGNED SECTOR AT ALL TIMES.
- (6) UPON COMPLETION OF THE EXERCISE, LOCK AND CLEAR THE WEAPON ON COMMAND. THE CHAIN OF COMMAND WILL ROD IT BEFORE THE AAR.
- (7) IF "CEASE FIRE" COMMAND IS GIVEN, STOP FIRING, ECHO THE CALL, AND PLACE THE WEAPON ON SAFE.
- (8) USE A VERBAL COMMAND, A RED STAR CLUSTER, OR RED SMOKE TO SIGNAL CEASE FIRE.
- (9) WHEN "CLEAR WEAPONS" IS GIVEN, PLACE THE WEAPON SELECTOR SWITCH ON "SAFE," REMOVE THE MAGAZINE, AND CLEAR THE WEAPON.
- (10) IF A WEAPON STOPPAGE OCCURS, INITIATE IMMEDIATE ACTION. IF IT CONTINUES TO MALFUNCTION, NOTIFY THE CHAIN OF COMMAND.
- (11) KNOW SECTOR LIMITS. DO NOT FIRE OUTSIDE OF THE SAFETY FAN.
- (12) KNOW THE SPECIAL REQUIREMENTS FOR THE RANGE.

Figure A-7. Example safety briefing for live fire (continued).

"During this exercise, safety is as important as the training. If everyone pays attention and does what they are supposed to do, we will have a safe LFX. Remember, safety is the responsibility of everyone in the LFX. Today we will be conducting a live-fire movement to contact. If you would direct your attention to the diagram, I will orient you to the terrain and enemy situation. Our sectors are as follows: (1) your left limit is _____, (2) your right limit is _____, (3) *(List any special restrictions such as limit of advance, degrees weapons may be fired above the horizon, where specified weapons may be fired, and so forth.)* (Fire control measures should be addressed in the OPORD.)

Figure A-8. Example safety briefing for a platoon movement to contact LFX.

"You will be issued ammunition at the assembly area located _____. At the assembly area, you will load the ammunition in your magazines, but leave your magazines in your ammunition pouches. Before moving out, everyone will be wearing their helmets and earplugs. You will lock and load your weapons on your squad leader's order after crossing Phase Line _____. At that time, all weapons will be on SAFE. When you positively identify targets after Phase Line _____, you may engage them IAW your OPORD or when ordered by your leader. You will never fire when someone is to your immediate front. Before moving, you will always place your weapon on SAFE. Ensure your barrel stays out of the dirt. If your barrel becomes obstructed, contact your chain of command, who will assist you. If at any time you see an unsafe act, you must call a cease fire. If you hear someone call "cease fire," cease firing, place your weapon on "SAFE," remove your magazines, and clear your weapon.

"If you have a weapons malfunction, initiate immediate action. If your weapon continues to malfunction, immediately notify your chain of command for assistance. Do not fall behind your squad at anytime.

"Upon completion of the exercise, your leader will order you to lock and clear all weapons. All weapons will be rodded. We will then conduct an AAR on the objective. You will then move back to the assembly area, collect all unexpended ammunition, and return it to the ammunition point."

Figure A-8. Example safety briefing for a platoon movement to contact LFX (continued).

A-7. INCIDENT REPORT FORMAT

In the event there is an accident, a malfunction, or incident on the LFX range, accurate information concerning the accident or incident must be relayed to the local range control in a timely manner. The unit should supply the information contained in the installation range regulations. If the installation range regulations does not address reports of accidents, malfunctions, or incidents on the range, the following information should be relayed to range radio control as soon as possible:

- Unit designation.
- Range and location.
- Type weapon involved.
- Type of ammunition involved.
- Brief summary of what happened.
- Personnel injuries, if any, and extent.
- Full name, rank, social security number, and unit of injured personnel.

- Extent of property damage.
- Intentions regarding further investigation.

A-8. MEDICAL EVACUATION FORMAT

If a casualty on the range requires evacuation, the procedures outlined in the installation range regulations should be followed.

- a. As a minimum, the following information should be given:
 - Accurate six-digit coordinates of pick-up site or described location.
 - Number, type, and condition of casualties.
 - Special equipment needed (for example, resuscitator, oxygen, blood, jungle penetrator).
 - Weather conditions at the pick-up site.
 - Description of ground markings (color panels, smoke, or improvised ground identification to be used).
 - Terrain description.

- b. The following procedures for directing aircraft are recommended:

- (1) Vehicle lights used for identification during night evacuation should be directed into the wind to allow the aircraft to approach over the top of the vehicle.

- (2) Smoke, when used, should be discharged as soon as the aircraft is within sight. Smoke should be on the downwind portion of the clearing to allow the aircraft to approach and land clear of the smoke.

- (3) Panels, when used, should be securely fastened to the ground about 5 to 10 meters upwind of the landing area. This must be done to prevent drawing the panels into the rotor blades.

- (4) The pick-up site and approach route must be clear of small-arms and artillery fire.

A-9. DUDS, MISFIRES, AND ERRATIC FIRING

The following paragraphs discuss safety considerations for duds, misfires, and erratic firing.

- a. **Duds.** Upon completion of firing outside of a permanent dud area, a thorough search should be made of the impact area. Duds should be marked and reported to range control for disposal. Marking should be IAW installation range regulations. A recommended way of marking duds is by stringing or laying durable material, engineer tape, or any distinctive expedient. Objects should not be driven into the ground and the dud should not be jolted in any manner. In addition to marking, a guide should be furnished to assist EOD personnel in locating the dud(s). A report should be submitted to range control IAW installation range regulations. The report will normally contain the following information:

- Coordinates of the dud's location.
- Location by terrain features.

- Number of duds.
- Type and caliber of dud.
- Method used to mark dud.
- Names of individuals available to assist EOD personnel in locating the dud.
- Name, rank, unit, and telephone number of the individual making the report.

(1) Upon completion of dud disposal by EOD personnel in nonpermanent dud areas, the range OIC will normally be responsible for submitting a written report to range control that a surface search has been conducted and all known duds have been reported or destroyed.

(2) When firing is conducted in a permanent dud area, a record should be kept indicating the number and caliber of duds observed or suspected. Upon completion of firing, this information should be submitted to range control.

b. **Misfires.** Misfire procedures for specific rounds are prescribed in the appropriate weapon or ammunition technical manuals and field manuals. These publications should be reviewed before conducting the LFX. When in doubt, the local ammunition supply point (ASP) or EOD should be contacted.

(1) If a small arms weapon misfires, it should be placed on "safe" and not fired again until it has been inspected and cleared.

(2) Before the turn-in to the ASP, misfires should be repacked into the original container, tagged or otherwise identified, and kept separate from other ammunition items. For mortar ammunition, safety pins should be emplaced in fuzes before turn-in. If the pin cannot be replaced, range control is contacted before transporting the round.

c. **Erratic Firing.** Any projectile that lands outside of the firing limits should be immediately reported to range control by radio. The report should include the approximate coordinates of impact, ammunition, caliber, estimated back azimuth, and time the round was observed. Personnel on the range should cease fire immediately and follow instructions from range control.

APPENDIX B

SITE SELECTION AND PREPARATION

This appendix provides information on considerations encountered by the Joint Readiness Training Center (JRTC) in emplacing their live-fire area. The JRTC's live-fire area is one of the best in the world and this information provides units with insight in selecting their own areas.

B-1. INTRODUCTION

The live-fire division of the JRTC conducts rifle platoon LFXs independent of force-on-force training. Platoon missions include movement to contact/hasty attack (MTC/HA), ambush of a vehicular convoy (AMB), and deliberate attack on a fortified position (ATK). Platoons execute one or a combination of these basic missions.

a. **Area of Operations.** *Each mission requires different resources.* For a platoon-level movement to contact, the unit needs a maneuver live-fire box approximately 1 kilometer by 4 kilometers in size. The best terrain is rugged, closed in, and densely wooded. Maneuver through the area requires surface clearance of dud munitions. Digging may be limited to targetry emplacement and trenchwork construction. While these areas must have subsurface clearance, subsurface clearing of the entire area might be impractical or near impossible.

b. **Scheme of Maneuver.** Assembly and rehearsal areas are designated in defensible, rugged terrain close to the line of departure. LFX areas should be rotated over time to reduce damage to the terrain and to allow vegetation to be as natural as possible.

c. **Construction.** Targetry is not permanently emplaced or hard-wired within the maneuver area. All targets and target mechanisms are hand-emplaced and, for the most part, are battery-powered and radio-activated.

d. **LFX Safety Procedures.** These procedures are established and enforced by the following:

(1) The commander is authorized to modify some provisions of live-fire operations as outlined in AR 385-63 to provide realistic conditions that replicate a near-combat experience. Range fans and small arms surface danger zones that extend outside the maneuver area/impact area have been waived IAW procedures stated in AR 385-63.

(2) The chain-of-command is responsible for safety. The leaders should stress safety practices inherent in the tactically sound principles taught by the mission training plan. Safe, realistic, and successful execution of the mission will result.

e. **Training Philosophy.** Live-fire training was developed and is executed under the following training guidance:

(1) The live-fire complex (maneuver box) is "non-standard"-it is not a range. LFXs are executed as tactical missions IAW an OPOD and ARTEP 7-8-MTP.

(2) The focus of training and execution is at the platoon and squad levels. The integration of other combat support assets is critical.

(3) Training emphasizes the employment of organic weapon systems at squad and platoon level. Indirect weapons systems are used throughout.

(4) Units are provided a realistic threat within a target-rich environment that presents each individual soldier the maximum opportunity to employ his weapon, and tests the ability of that platoon's chain-of-command to control and distribute fires effectively.

(5) Platoons conduct planning and dry-fire rehearsals on terrain similar to the objective but not the actual objective. The only time a platoon sees an actual objective before mission execution is if that particular task requires a leader's reconnaissance. Platoons also receive a minimum of four to five hours sleep within 25 hours before mission execution.

f. **Unit Feedback.** Observer-controllers (OCs) observe execution of the LFXs and provide feedback to the maneuver unit in AARs conducted on site after the completion of each event. They accomplish this by observing unit performance, controlling external factors, teaching doctrine, coaching the chain-of-command, conducting the after-action review, and monitoring safety.

B-2. SITE DEVELOPMENT

Site development determines the composition of the live-fire complex and the surrounding area. The following are recommendations for units to use in the site development process.

a. **Site Selection.** The ground tactical plan should be developed first and then terrain found to meet the needs of that mission. Often this does not happen and the mission is modified to fit the terrain.

(1) The size of the impact areas and their proximity to civilian areas is a limiting factor. Environmental concerns also impact on site development ranging from Red-Cockaded Woodpeckers in North Carolina to endangered snails in Hawaii.

(2) All posts are not alike and are subject to different MACOM, installation, and range control safety limitations. The commander's guidelines and restrictions must also be considered.

b. **Site Reconnaissance.** The three steps in the initial reconnaissance are:

(1) Analyze the desired terrain based on the safety restrictions IAW post regulations, commander's guidelines, and the surface danger zones (SDZ) IAW AR 385-63. Consider these first before selecting terrain.

(2) Walk the terrain and carefully mark all desired target positions on the ground and confirm each grid location to an eight-digit grid coordinate using PADDs.

(3) Develop a detailed training scenario and sketch of the live-fire event. Include in the scenario development: target locations, planned routes to support, expected locations where the unit initiates direct fire, and so forth. This scenario must include all actions that the unit conducts from occupation of an assembly area to the conclusion of the mission and consolidation on the objective.

c. **Surface Danger Zones.** A key to receiving range control approval of the LFX plan is the creation of an accurate composite SDZ overlay. SDZs must strictly adhere to constraints in AR 385-63 and local SOPs. Early and continuous coordination with range control on SDZs is recommended. Range control can greatly simplify the process of determining the SDZ and decipher local safety requirements.

d. **Target Emplacement.** Targets must be emplaced to closely replicate how the enemy will fight. The construction of objectives must be doctrinally correct. Every effort must be made to portray a credible enemy force that fights back and forces units to execute their battle drills. This enemy must be tough and realistic, and inflict casualties on the attacker.

APPENDIX C

LIVE-FIRE TRAINING ENHANCERS

The use of training enhancers on an LFX is limited only by the trainer's imagination. Trainers can easily create the effects of the "dirty battlefield" complete with enemy dead, obscurants, and noises. The guiding principles are that anything used to enhance training must be safe and effective. The following techniques are safe and effective when applied with common sense on the LFX range. By using the training enhancers in this appendix, the following battlefield environment effects can be simulated: realistic targetry, smoke, fire, indirect fire, machine-gun sound, sniper fire, general battlefield sound, battlefield illumination, mines, booby traps, casualties, chemical weapons effects, and nuclear weapons effects.

C-1. CASUALTIES

Enemy dead are easily created using salvaged code X fatigue uniforms, helmets, and boots from the local Defense Reutilization Office. The enemy should not be dressed in the same uniform as the soldiers conducting the training. The fatigues and boots can be stuffed with newspapers, straw, or other filler material and the head can be made of stuffed paper bags painted to resemble a face. Plastic enemy small-arms weapons can be obtained from the local TSC and used to litter the battlefield. Red paint makes excellent blood. The homemade dummies can be dressed up with enemy identification documents, maps, and other identification available from TSC or easily created in the unit. The easiest realistic casualties are created by dressing E-type silhouettes in salvaged uniforms and splashing them with red paint.

C-2. SMOKE

The traditional means of creating smoke on the LFX range is to use smoke grenades, smoke pots, smoke generators and artillery or mortar smoke rounds. Expedient materials can be ignited immediately before the LFX or can be remotely ignited during the LFX by using time fuse.

C-3. INDIRECT FIRE

The best means of simulating indirect fire is to use indirect fire on the target array. Soldiers will normally not be allowed to maneuver into

permanent artillery impact areas because of the possibility of duds. Temporary impact areas may be established, if necessary. With concurrence of range control, certified ammunition may be fired into a temporary impact area, which is later to be maneuvered through. Participants should be alert to the possibility of duds and take appropriate action if one is encountered. After the exercise is completed, the user clears the area with the assistance of the explosive ordnance detachment (EOD).

a. Units may maneuver in proximity to indirect fire under certain conditions. Soldiers and vehicles involved in training may operate under the artillery gun-target line in certain areas during firing. Armored vehicles may maneuver under air bursts if variable time (VT) or time fuses are used on certified ammunition, and if the firing data meet certain conditions explained in paragraph 11-5e, AR 385-63. In this specific case, all downrange vehicles must remain buttoned up or in the protected open (clamshell) position during firing.

b. Personnel may occupy approved bunkers within 200 meters of impacting artillery in areas surrounding the impact area. However, this situation must be planned to fit into the LFX scenario.

c. When indirect fire support is supplied by mortars, mortar firing points must be planned to avoid firing over the head of soldiers. In order to increase the training benefit for the mortar crews, the exercise could be planned to cause mortars to displace and provide continuous support. By keeping the mortars almost adjacent to the firing unit, the doctrinal principle of keeping them well forward is trained while precluding a need for overhead fire. Many of the safety considerations discussed for field artillery are applicable to mortars.

d. A certified safety officer must be on the mortar point. The location of the maneuver unit must be known by the mortar platoon or section leader and FSO so they can ensure that the surface danger zone is enforced with respect to the gun-target line. If the mortars are fired from direct lay, verifying friendly unit positions is relatively easy.

e. If the decision is made not to use indirect fire on the range, artillery can be simulated by using electrically primed TNT blocks. These blocks can be used to create a rolling barrage that can be "walked" within 25 meters of the firing line. Artillery simulators can be used to supplement the barrage and to simulate fire received to the rear of the unit. These explosions also contribute to the battlefield haze by producing small dust clouds.

f. In addition to TNT explosives, the propane-oxygen artillery simulator is an excellent means of simulating incoming artillery rounds. Also, remote receivers of the THM-TG and RMB can command detonate any electrical firing explosive device including C4 and Hoffman devices.

Each device can produce up to three separate events. Placed in critical locations and activated at the right time, these explosions sound authentic to maneuvering units. Smoke pots can be detonated on the objectives also.

C-4. EXPLOSIVES

Explosives use a surface danger zone involving only a bursting radius. Unprotected soldiers are not authorized within the bursting radius, as discussed in Chapter 18, AR 385-63. To integrate explosives into the LFX, soldiers must not be within the prescribed radius once the munition is armed. In defensive scenarios, explosives can be pre-positioned and remotely armed and detonated. In offensive scenarios, bangalore torpedoes and line charges can be used. If actual bangalore torpedoes are not going to be used on the range, camouflage net poles can be used at a pre-positioned breach point and a small explosive charge set off to breach the obstacle.

C-5. BATTLE SOUNDS

Battle sounds can be created by prearranging with the local TSC to have loud speakers and battle sound tapes played on the range. (This is done at JRTC.) Another possibility is to arrange support from local PSYOP units.

C-6. ENEMY FIRE

Enemy fire can be simulated by having a pneumatic machine gun positioned downrange with the remote firing device operated from a concealed position behind the firing line. At night, enemy fire can be simulated using the night muzzle flash simulator for the RETS target and the infantry hostile fire simulator (Figure C-1). Enemy ATGM fire can be simulated using electrically wired ATWESS charges downrange.

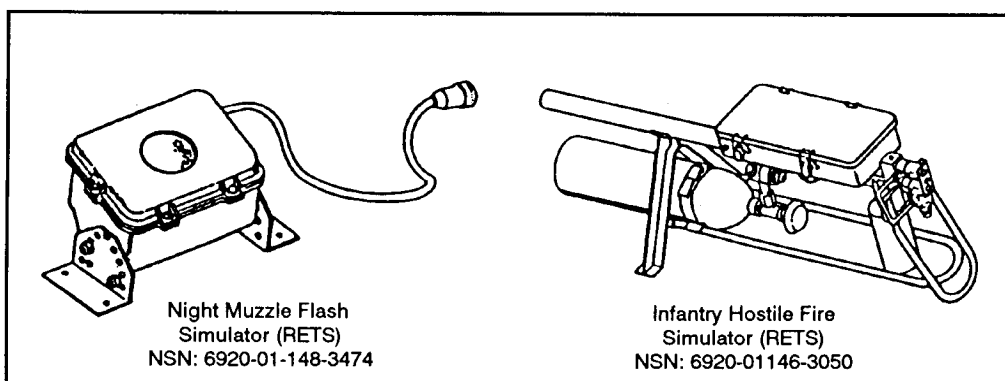

Figure C-1. Simulators.

C-7. CHEMICAL CONTAMINATION

Chemical contamination can be simulated by various means. Perhaps the simplest is to sprinkle liquid vegetable oil on bushes that the maneuver unit will go through thereby simulating liquid agent contaminant. SPALS

(simulator, projectile airburst liquid, M9, DODAC 1370L595) can be used to simulate the burst of a chemical round. Coordination with the battalion chemical officer will disclose other ways to simulate a contaminated battlefield. The chemical officer will be able to assist in any pre-training required before conducting an LFX in a contaminated environment.

C-8. LAND MINES

Except for Claymores, training with live land mines has been discouraged, although current regulations permit their use. When using live mines for training, all applicable regulations must be followed. Therefore, units planning to incorporate land mines (other than Claymores) into a defensive LFX should usually plan on using plastic land mines from TSC for practice in laying hasty protective minefield. For offensive LFXs, the M21 smoke-producing antitank mine (DVC-T 23-31) can be used. This mine is a full-scale, three-dimensional plastic replica that has the size and appearance of the actual M21 with tilt rod, M605 fuze, and M18 smoke grenade (colors: yellow, green, violet, and red). The mine is expendable, but it can be used three to five times before being damaged. The M605 fuzes and M18 smoke grenades must be requisitioned through normal supply procedures. Antipersonnel booby traps can be created using trip wire and nonexplosive smoke grenades and illumination devices. Pressure activated antipersonnel mines can be created using the ends of Number 10 cans, a battery, camera flashbulbs, and communications wire and booby trap techniques (Figure C-2). The booby traps and connecting wires are buried near the surface. When a soldier steps on any of the mines, the central flashbulb explodes injuring soldiers in the immediate vicinity. The mines can be easily located by probing.

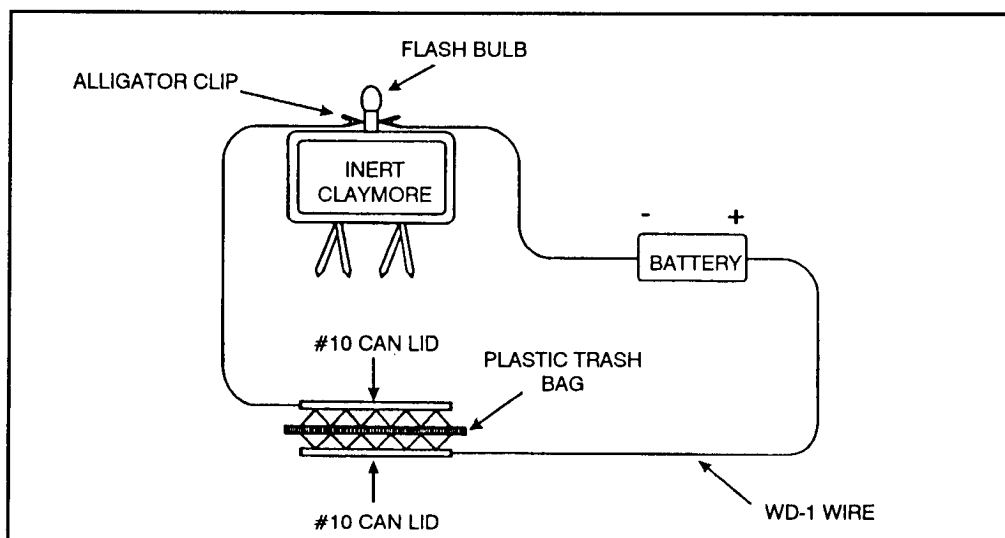

Figure C-2. Flashbulb land mine.

C-9. NONCOMBATANTS ON THE BATTLEFIELD

Because friendly units can expect to encounter noncombatants or civilians as they fire and maneuver, TOMI targets in civilian attire are mixed into the target arrays to further confuse the battlefield. The friendly units must identify civilians and react according to the rules of engagement.

C-10. SMALL ARMS FOR AIR DEFENSE

An excellent way of cueing SAFAD is through the use of the radio-controlled miniature aerial target (RCMAT). The RCMAT is an aerial target that is used for air defense training. It can be tracked throughout the effective range of small-arms weapons used in air defense. The target is recoverable and has a 15-minute endurance time. To coordinate RCMAT support for the range, the installation's TSC must be contacted. The TSC will usually control the device during the exercise. Prior coordination must also be made with range control due to the increased surface danger zone required because of elevating small-arms weapons to engage an aerial target (Figure C-3).

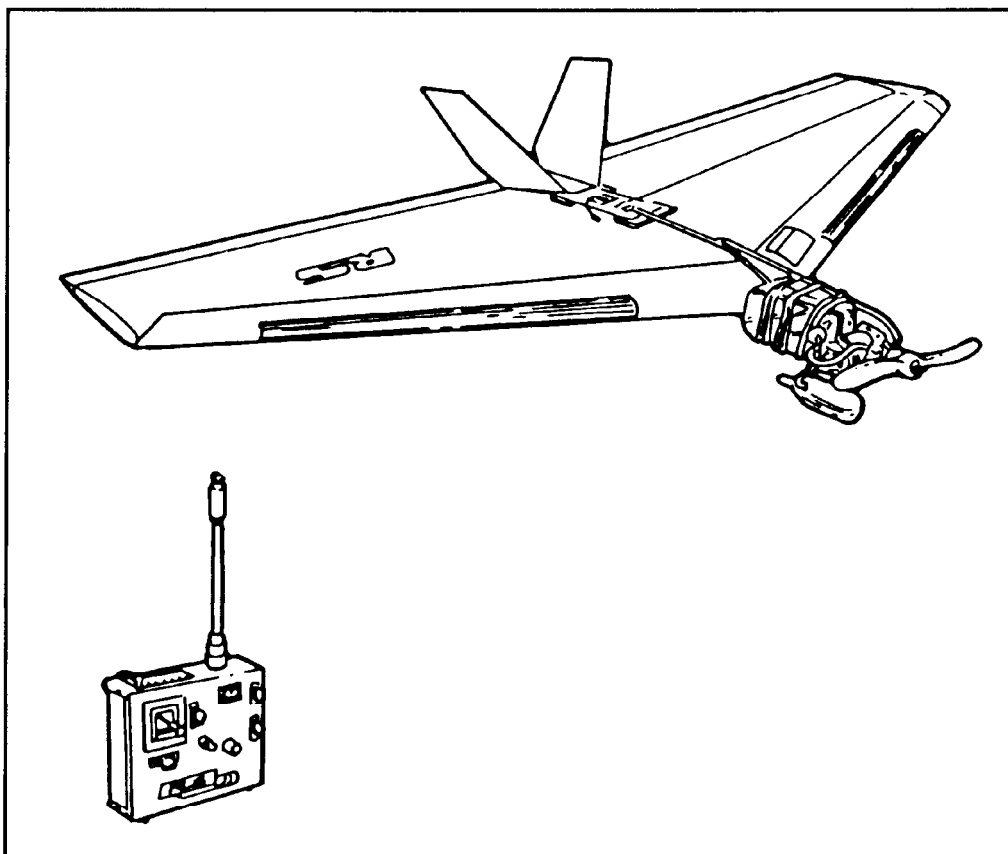

Figure C-3. Radio-controlled miniature aerial target.

C-11. TARGETRY (FIELD-EXPEDIENT AND PORTABLE TARGETS)

Field-expedient targets are simple, low cost, live-fire targets that are easily made within the unit using material that is readily available. Field-expedient targets can be used to supplement standard targets or in place of standard targets. Using field-expedient targets allows a unit to accurately portray a realistic threat array by ensuring that adequate targets are available to suit the scenario and the size unit being trained. Field-expedient targets are of two types: personnel and vehicular.

a. **Personnel Field-Expedient Targets.** Personnel targets are stationary or moving. (See Figures C-4 through C-9.)

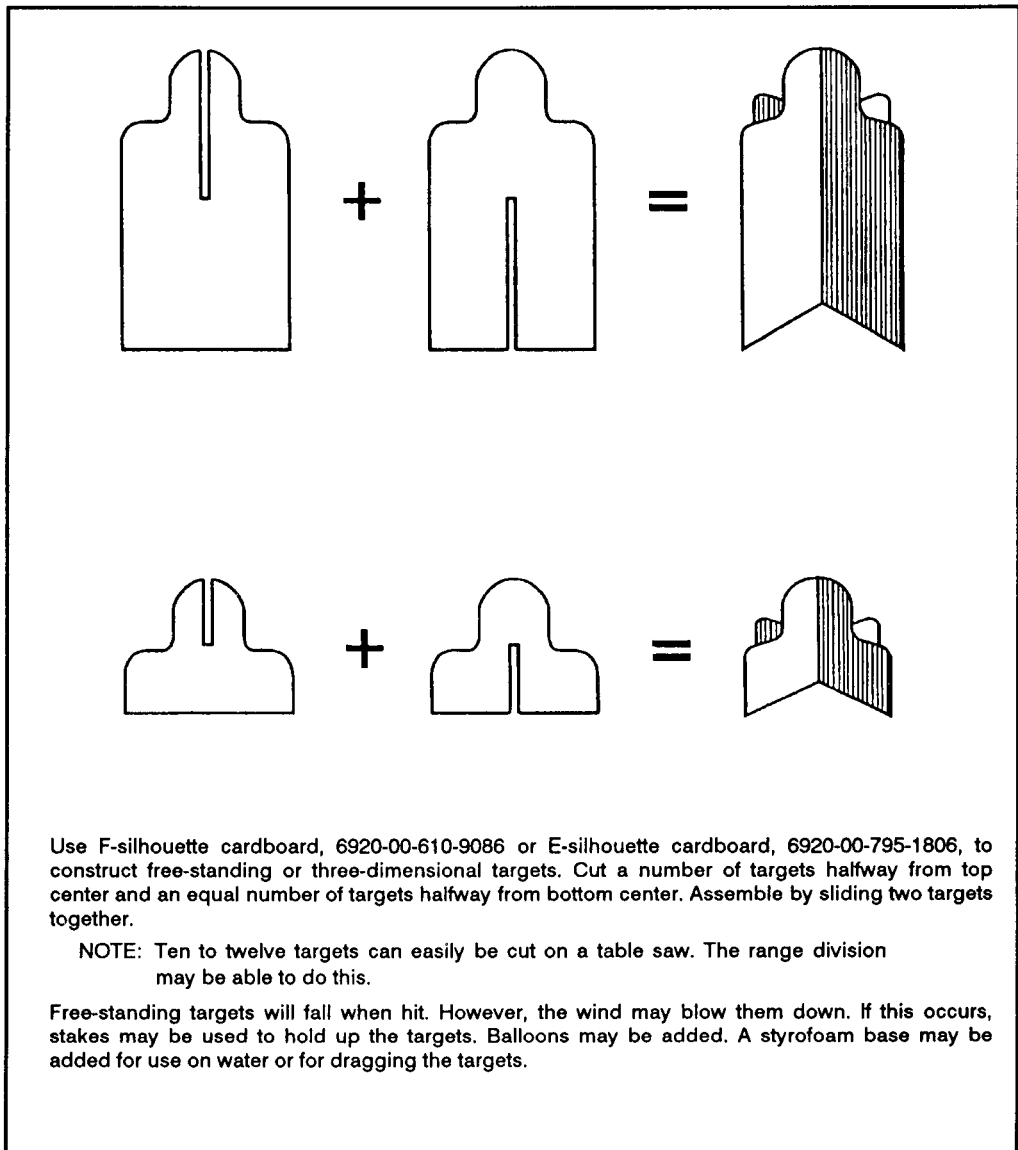

Figure C-4. Three-dimensional targets.

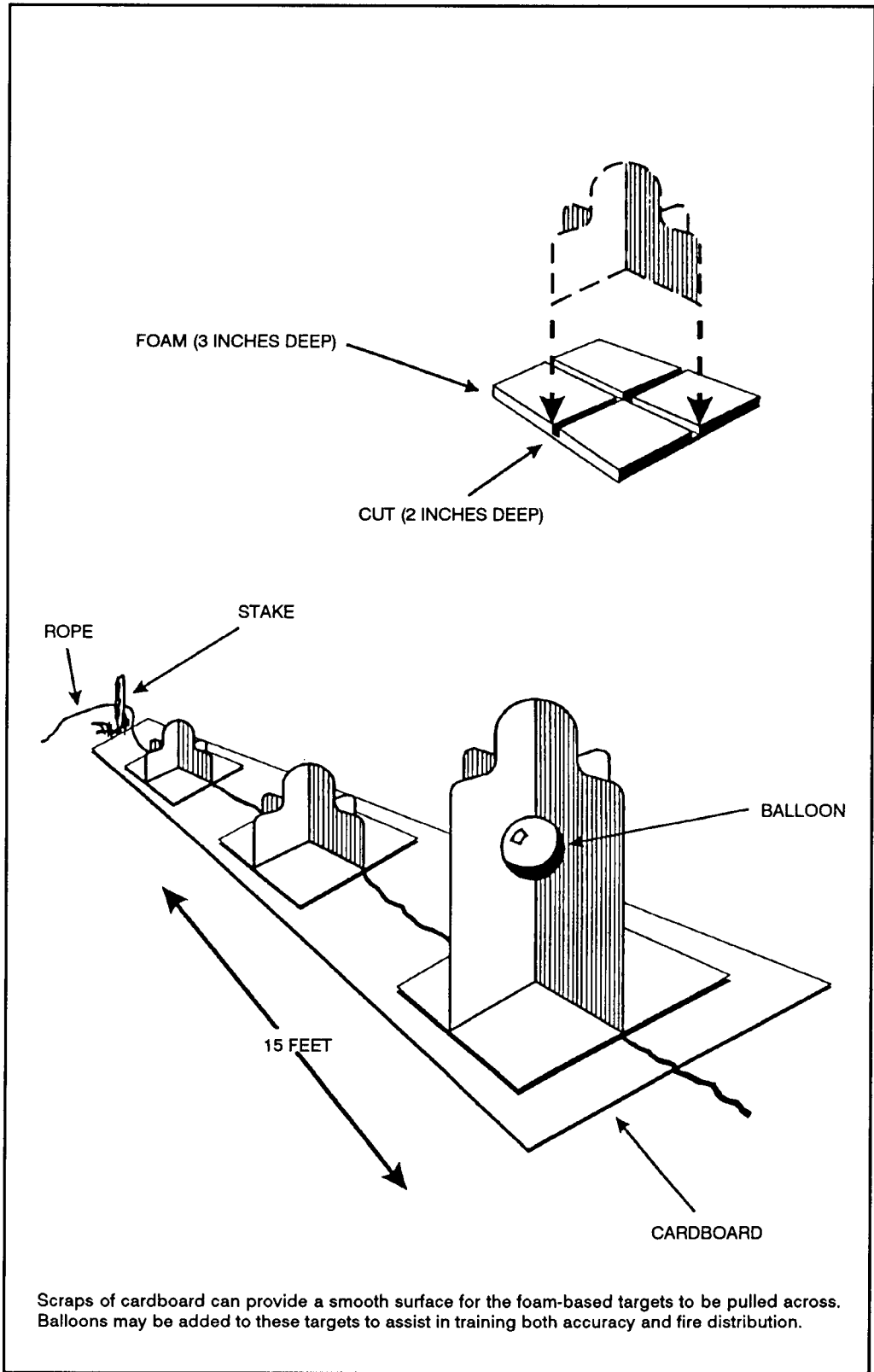

Figure C-4. Three-dimensional targets (continued).

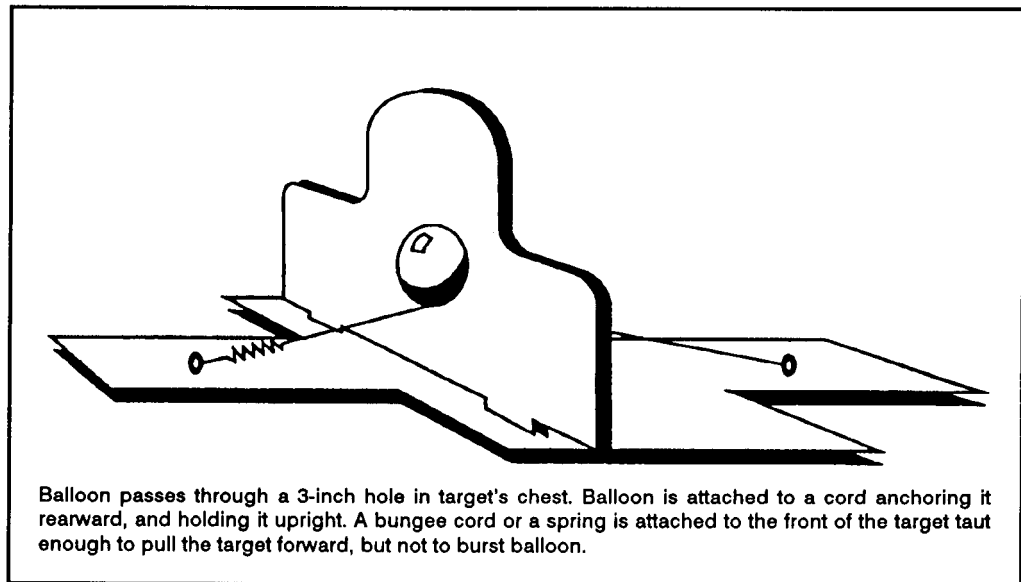

Figure C-5. Stationary falling personnel target.

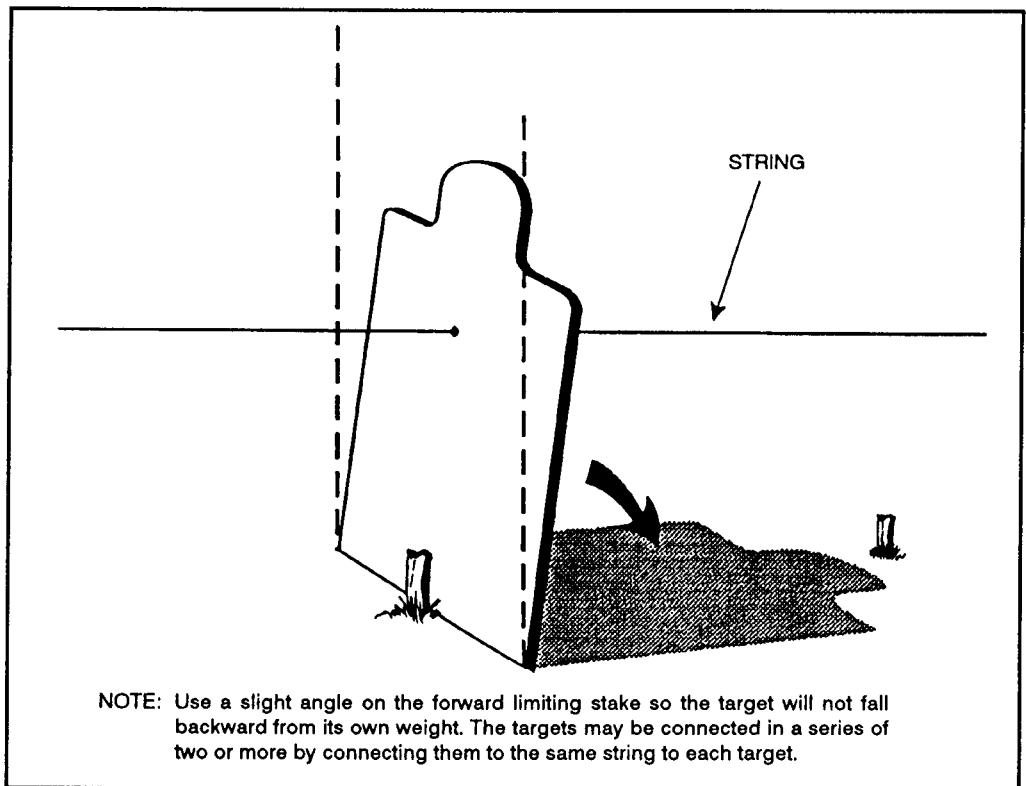

Figure C-6. Command-raised stationary personnel target.

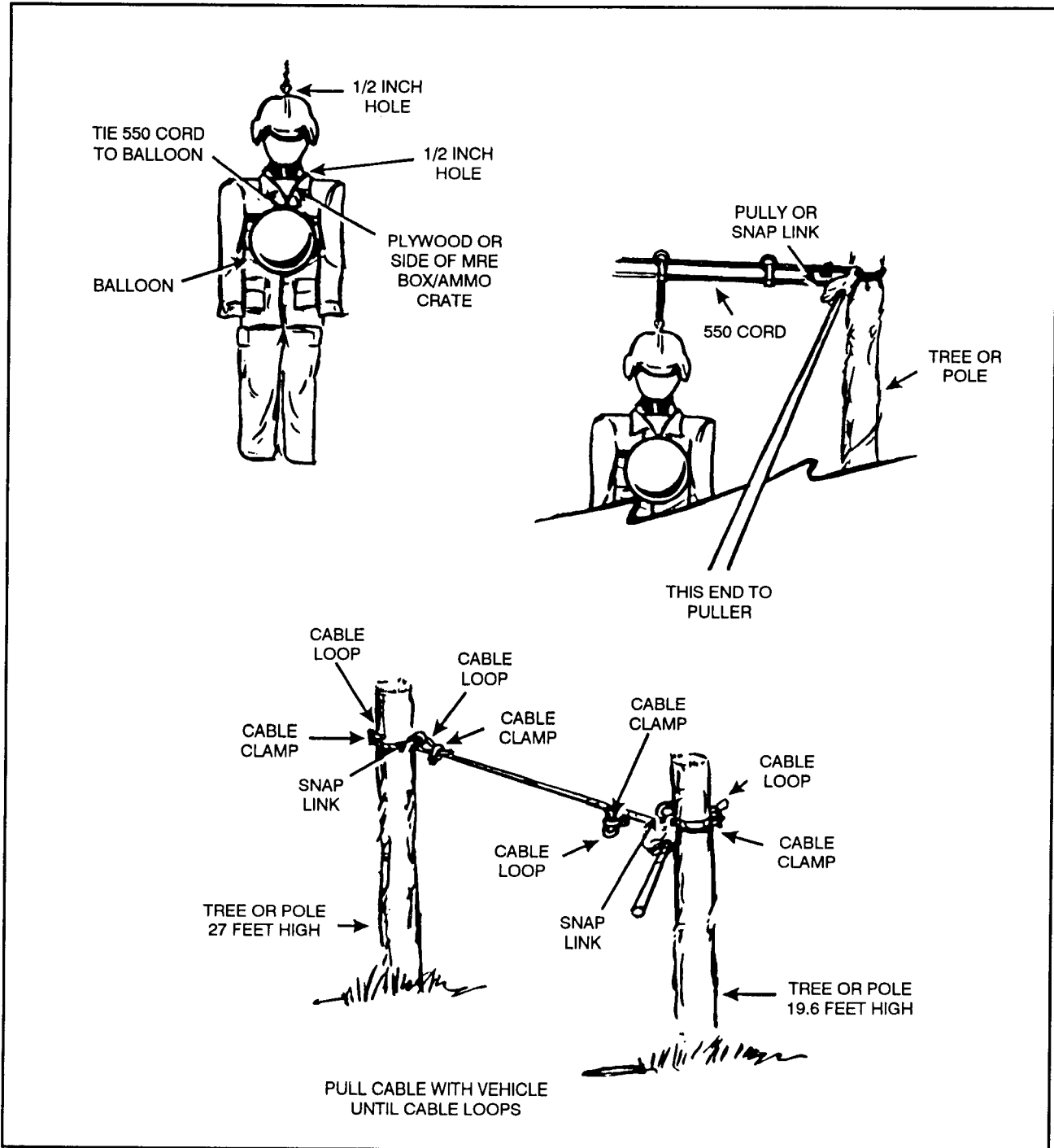

Figure C-7. Moving personnel falling target.

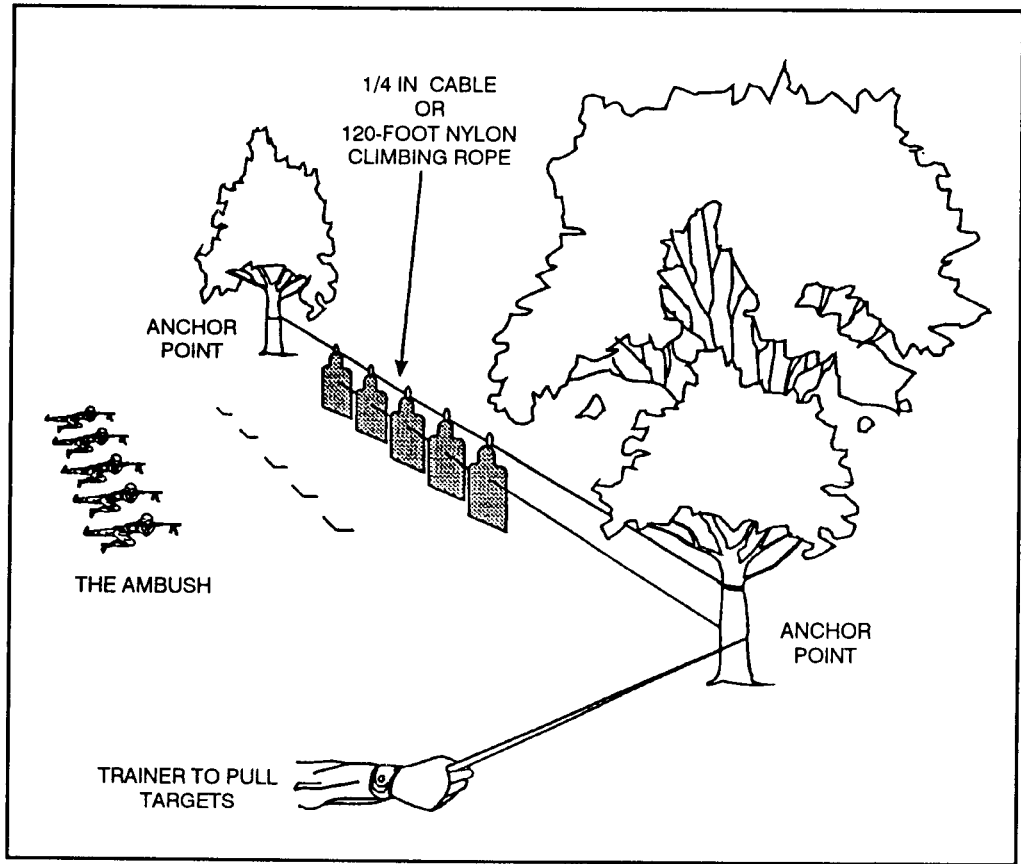

Figure C-8. Multiple moving personnel targets.

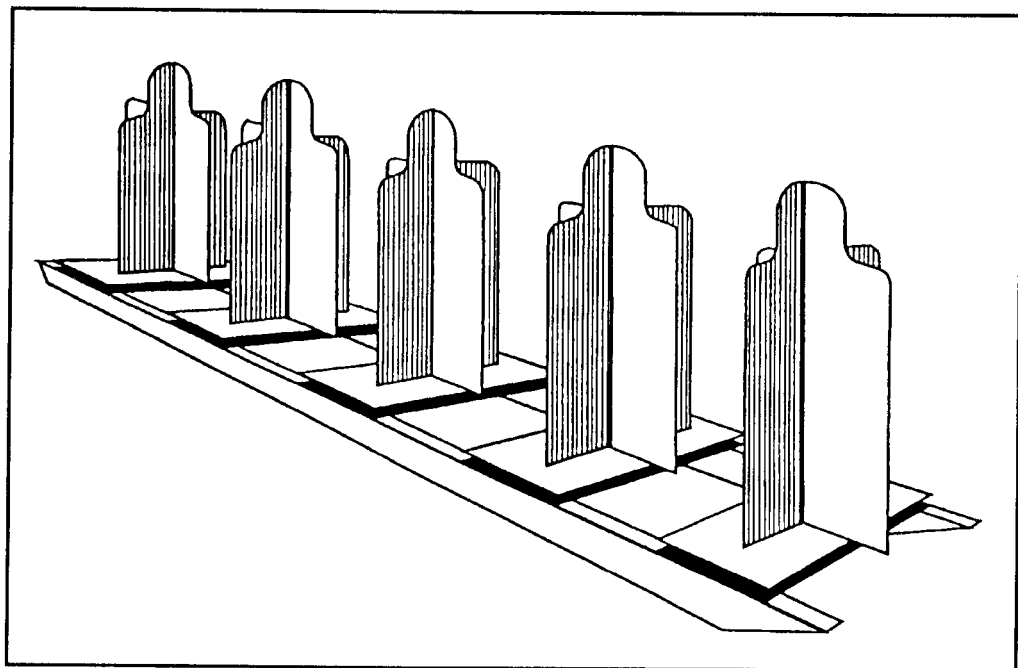

Figure C-9. Three-dimensional personnel target sled.

b. Vehicular Field-Expedient Targets. Vehicular field-expedient targets are stationary or moving. The best vehicular target is a vehicle itself. Salvaged vehicles for use as targets are available through the local Defense Reutilization Management Office (DRMO).

(1) **Getting a salvage vehicle.** The battalion S4 must coordinate with local post authorities to ensure that such targets are permitted on the ranges. The request must clearly state that the vehicle will be used as a target for an LFX and indicate the type of vehicle that is required (truck, jeep, other). If the DRMO does not have the vehicle locally, it can coordinate with other DRMOs to transfer the property, but the unit may have to pay associated transportation costs. Before placing the vehicle on the range, coordination must be made with range control. The unit must be prepared to dispose of the property after the LFX is complete. The property will routinely be turned back in to the local DRMO as scrap metal.

(2) **Preparing a salvage vehicle.** If the vehicle still has an engine block or other heavy metal structures that could cause ricochets, the unit should either remove the engine block or structure, or pad it with sandbags.

(a) The vehicle should be purged of fuel and oil and the battery removed to prevent hazardous waste spill during the LFX. Waste fuel and oil are disposed of IAW local SOP.

(b) Any US Army markings should be painted over.

(c) If the scenario calls for the vehicular target to move, it will need to be hooked to a prime mover outside of the surface danger area of the LFX. Two ways of doing this are straight pull or pulled through a "dead man." A straight-pulled vehicle is attached directly to the pull vehicle by a metal cable and pulled in the direction of travel (Figure C-10, page C-12). A vehicle pulled through a "dead man" is attached to the pull vehicle in the same manner as the straight-pulled vehicle, but at an intermediary point it is attached to a "dead man" that allows the pull vehicle to be offset from the direction of pull (Figure C-11, page C-12). In both techniques, the pull vehicle must have sufficient power to pull the target vehicle; if a "dead man" is used, it must be heavier than the vehicle being pulled. The cable used must be strong enough to withstand the tension involved. As a safety measure, only the pull vehicle driver and assistant driver should be permitted within twice the total distance of the cable to prevent injuries if the cable snaps. The driver and assistant driver should be in the cab of the vehicle and should wear helmets throughout the LFX. The assistant driver looks toward the pulled vehicle and notifies the driver if the pulled vehicle experiences any problems. To prevent the cable from snapping if shot during the LFX, the pull vehicle should cease pulling after the target is engaged. If the scenario calls for the target to be pulled after it is engaged, multiple cables should be used and the target should be pulled slowly.

(d) Vehicular targets can also be made of cut plywood or other material painted to resemble the type vehicle desired. FM 25-7, Appendix B has examples of the dimensions required.

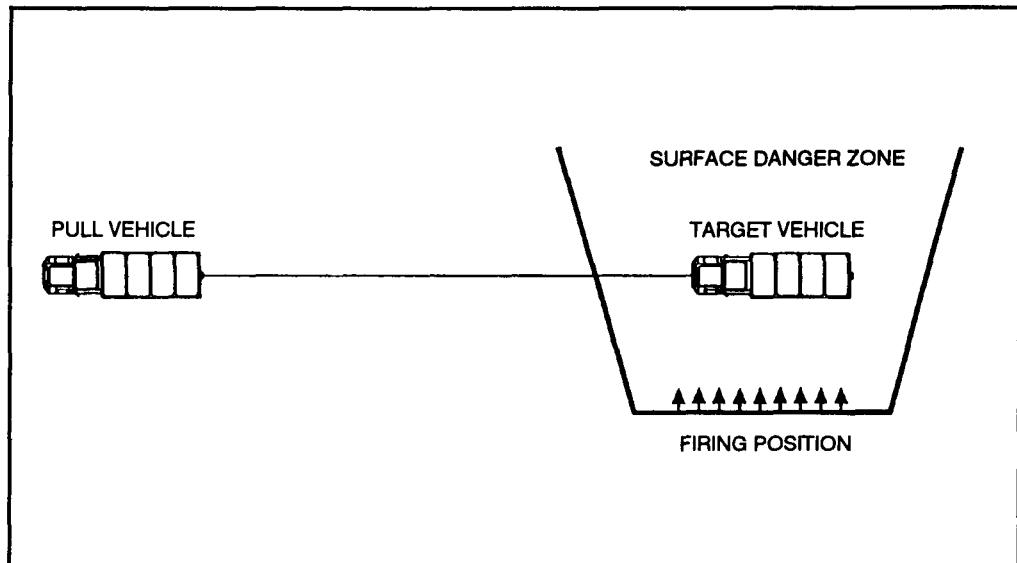

Figure C-10. Straight pulled vehicle for ambush.

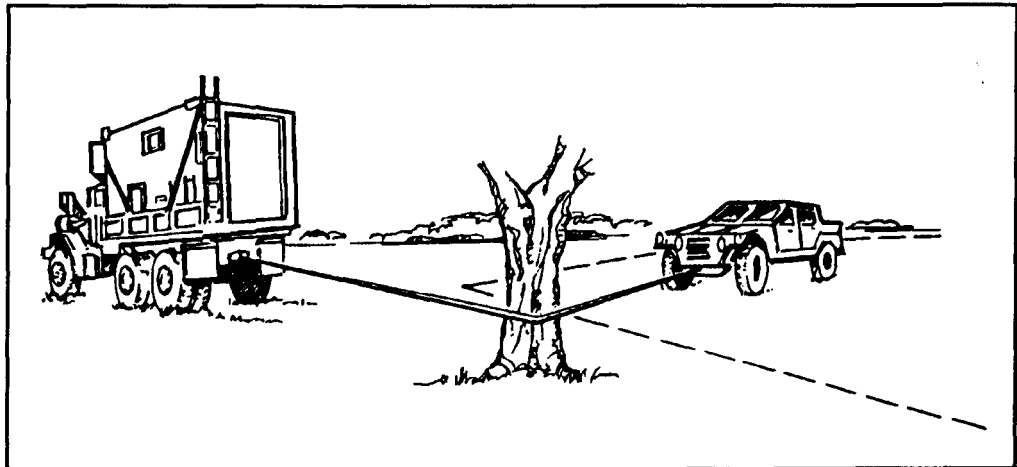

Figure C-11. Vehicle pulled through a "dead man."

c. **Reduced Scale Vehicular Targets.** Reduced scale targets are discussed and illustrated in FM 25-7. Reduced scale 1:5 and 1:10 vehicle targets can be used with the M31A1 target mechanism (Figure C-12) to simulate enemy vehicles. These targets have the advantage of being command controlled, portable, and are usually available on large installations. These targets can easily represent an attacking force by arraying the targets in depth and moving the targets toward the firing line. The targets are especially helpful in simulating a counterattacking enemy

force. To simulate a counterattacking enemy force, targets beyond the objective are left in the down position during the assault and consolidation phases of the LFX and are activated as a counterattack force. Reduced scale targets may also be used on a reduced scale range as part of LFX preparatory training to train the platoon or squad in fire control procedures.

d. **Portable Targets.** The standard portable target used on LFX ranges is the target holding mechanism, trainfire (NSN: 6920-00-657-7533, Figure C-13). It has a primary voltage (input) of 120 and 240 VAC and a secondary operating voltage of 12 to 24 VDC. For use on field ranges, the target holding mechanism normally operates on 12 VDC using 12 VDC car batteries. These batteries have a tendency to freeze at temperatures below 32 degrees Fahrenheit. When operating in low temperatures, fully charging the batteries the night before and installing them in the targets immediately before use is recommended. (For more information on the M31A1 mechanism, see TM 9-6920-203-14.) Several other portable target types are available. To determine what is available locally, local range control should be contacted.

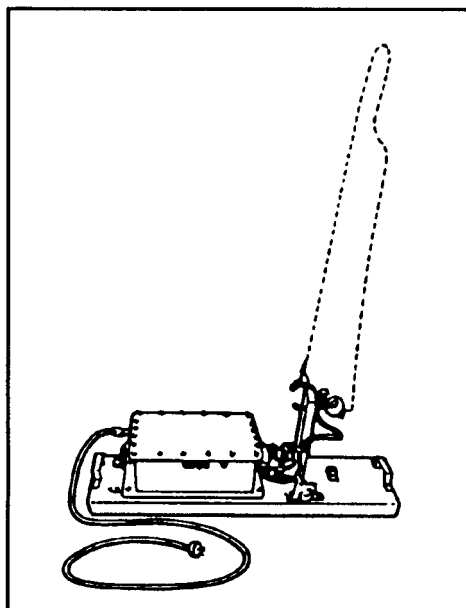

Figure C-12. M31A mechanism for 1:5 and 1:10 scale.

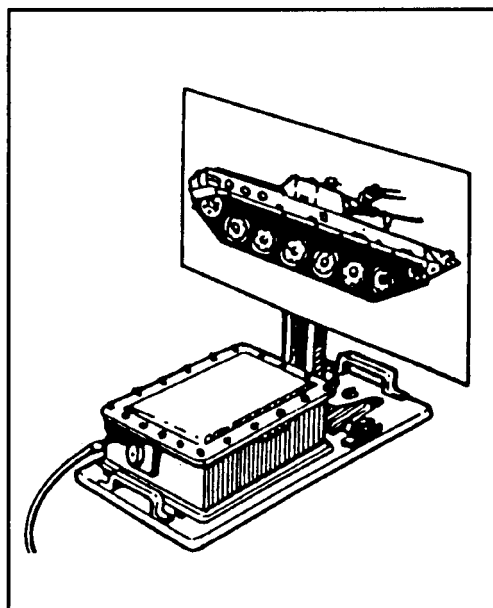

Figure C-13. Target holding mechanism, trainfire.

C-12. SUBCALIBER DEVICES

Subcaliber devices are available for the LAW, AT4, and 90-mm antitank weapons and can be used as part of the LFX when the proper antitank ammunition cannot be obtained. These devices are cheaper to use than service ammunition and can usually be obtained more easily. The

battalion or brigade S4 has information for the types and amounts of subcaliber ammunition available.

C-13. PLASTIC AMMUNITION

The Army currently has short range training ammunition for the M16 rifle and .50 caliber machine gun. SRTA (plastic ammunition) consists of M862 for the M16A2, and M858 (ball) and M860 (tracer) for the .50 caliber machine gun. Fielding of plastic ammunition for 7.62 (M60) and 55.6 drum (M249) is anticipated in the near future. This ammunition allows safe, realistic training at shorter ranges. It is particularly useful for MOUT training because it does not ricochet. Plastic ammunition should never be used in a support by fire role because of its limited range. It is as lethal as ball ammunition; therefore, appropriate safety precautions must be taken.

a. **5.56-mm M2 Bolt Assembly.** The M2 bolt is used to adapt the M16-series rifle to fire the M862 SRTA. The M2 bolt converts the action of the rifle from gas operation to blowback operation. It is a direct substitution for the standard M16 rifle bolt with no additional modification of the rifle required. Fielding of new bolts is anticipated in late 1993.

b. **.50 Caliber Machine Gun M3 Recoil Amplifier Barrel Assembly (RABA).** When the machine gun is under-powered, the M3 HB machine gun RABA provides the means to boost the power to the level required to recoil the barrel and effectively cycle the weapon.

(1) Because .50 caliber SRTA enables realistic training at shorter distances with greatly reduced danger areas, the use of standard M33 ball (service) ammunition with its extended range must be restricted when the RABA is attached to the weapon. A discriminator must be installed in the feedway of the gun when the RABA is in use. This discriminator restricts the entry of M33 service ammunition into the feedway of the M2 HB machine gun, but permits the shorter training cartridges to feed.

(2) Machine gun RABAs are scheduled for full-scale release in late 1993.

C-14. LIVE-FIRE EXERCISE RECORDING

The Sony TV Rover is an excellent means of recording the LFX so that it can be reviewed during the AAR or at a later time. The kit can be obtained from TSC and contains three major parts (plus battery packs): a portable television, a hand-held camera with monopod, and a video cassette recorder (VCR). The system can be used with any 110-volt power source or with the battery pack for mobile taping. When taping is complete, the film can be monitored on the television set.

APPENDIX D

SPECIAL CONSIDERATIONS FOR NIGHT EXERCISES

At night, LFXs are inherently more complex due to the increased difficulty of control, target identification, location identification, and execution. Controlling movement and checking positions of personnel and vehicles is more difficult. Every precaution must be taken to ensure the safety of personnel. A plan for night firing contains all of the details of day firing with additional considerations to ensure successful training and safety. This appendix deals with the special considerations for conducting an LFX at night. The following considerations must be incorporated into planning and execution unless METT-T factors prevent it.

D-1. REHEARSALS

Rehearsals are critical to prevent personnel from becoming disoriented and to check control procedures and marking techniques. Rehearsals must be conducted first during daylight to orient personnel and then at night to test control procedures and equipment.

D-2. MARKERS

Markers are the devices used by the unit to control fires. They should not restrict tactical play.

a. Infrared lights (either chemical, LEDs, or others) can be used to mark the sector limits to ensure firing stays inside the prescribed areas. This method is visible through most NVDs but cannot be seen by the unaided eyes. The unit must have AN/PVS-4s for individual weapons for this method to be most effective. Safety personnel (OCs) must also have NVDs. Chemical lights are plainly visible at all times, but are not bright enough to interfere with tactical play. Using chemical lights also reduces the requirements for NVDs.

b. Targets can be marked (to simulate realism) so they can be detected by the means available to the maneuver unit. FM 25-7, Appendix B, contains techniques for marking targets for thermal detection and identification. FM 25-7 describes a reflective target that can be used with night muzzle flash simulator (RETS, NSN 6029-01-148-3474) to simulate a muzzle flash.

c. The maneuver unit should use its own marking system consistent with the tactical situation and safety limitations. The unit should consider using the following techniques consistent with METT-T and local safety regulations.

(1) If the tactical situation will allow, the unit should mark its own routes as part of the reconnaissance. This will help to prevent disorientation as the unit maneuvers toward its objective.

(2) Positions should be marked to assist entry into the position, weapons orientation, and exit from the position.

(3) Control points should be marked by the maneuver unit to ease navigation and control problems. The marking should be done as part of the unit's reconnaissance of the objective area, consistent with METT-T.

(4) Individual soldiers should wear luminescent tape on their helmets or caps for identification and to ease control.

D-3. NIGHT VISION DEVICES

Night vision devices are necessary for personnel to work effectively if infrared lights or thermal markers are used.

a. The AN/PVS-4 is necessary for each weapon if the range limits are marked with infrared lights. The AN/PVS-5 or -7 is necessary for leaders to follow routes marked with infrared lights. During movement, AN/PVS-5s will be necessary for control personnel (OCs or chain of command) to track the unit.

b. The AN/TAS-5 and AN/PAS-7 are thermal viewers. They can be used for target identification if thermal targets are used or for identifying range limits marked with thermal markers.

D-4. COMMUNICATIONS

Communications requirements are the same for a night live-fire range as they are for a day live-fire range, except plain red star clusters are used as an emergency cease fire signal instead of red smoke. Red smoke cannot be seen at night. The maneuver unit should plan all of the normal communications for a tactical operation to include radio-listening silence. The unit should never leave its radios behind because they may be needed for an emergency even if they are not needed during the exercise itself.

D-5. LIGHT AND WEATHER DATA

When a night LFX is planned, the light data must be considered. A full moon will greatly enhance command and control. A new moon will make navigation and orientation more difficult and increase dependence on NVDs. As the time for the night fire draws near, the weather should be monitored. A heavy overcast will negate the effects of the moon and stars.

D-6. ILLUMINATION

Illumination should be planned by the firing unit as it would be in combat, even if the firing unit does not intend to use fire support. The following types of illumination have different planning considerations.

a. Flares are normal signaling and illumination devices for units in night operations. They are used at command discretion and included in the safety briefing.

b. The M203 may be used for signaling or limited illumination using the 40-mm smoke, star cluster, or smoke rounds. This is a good expedient method of illumination.

c. Mortars provide excellent illumination, but the firing fan must be offset from the maneuver unit to avoid firing over the heads of the soldiers (Figure D-1).

d. Artillery provides excellent illumination but must be coordinated for in advance. Firing points must be surveyed in advance.

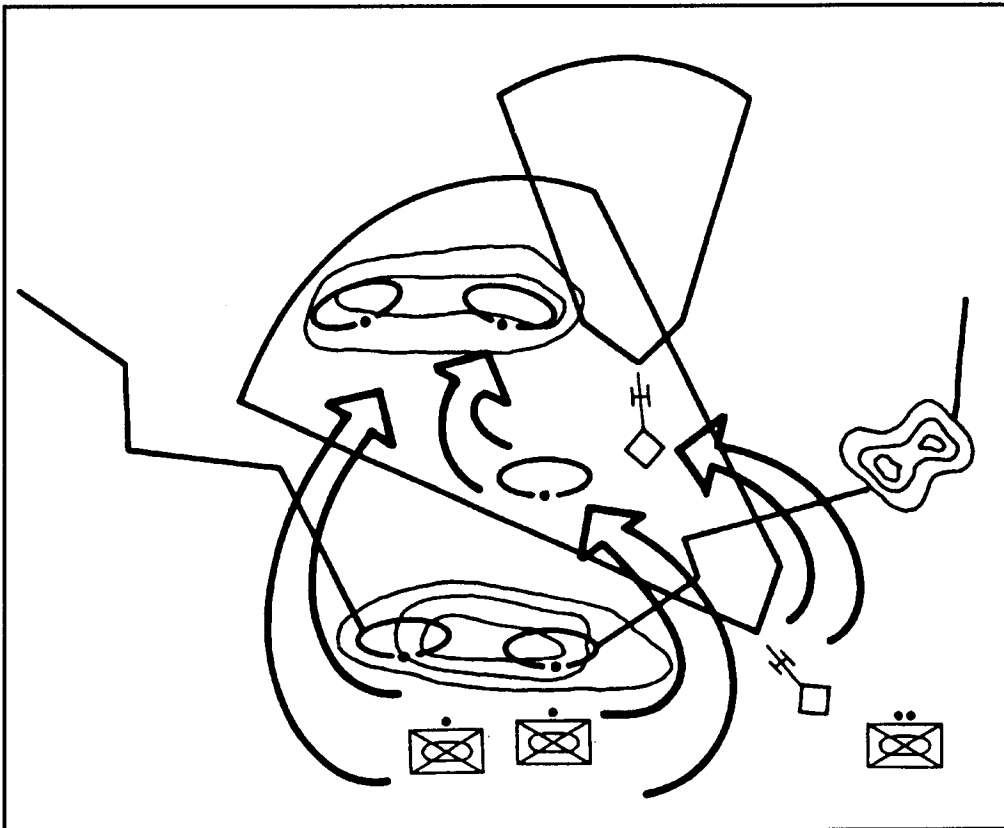

Figure D-1. Mortar positioning for live-fire exercise.

APPENDIX E

LIVE-FIRE LESSONS LEARNED (JOINT READINESS TRAINING CENTER)

By August 1990, over 23 maneuver based platoon-level LFXs had been conducted at the JRTC. Platoons were detached from the force-on-force and attached to a notional company in the live-fire area for the conduct of each exercise. Three missions were conducted: (1) movement to contact; (2) ambush; and (3) attack. The movement to contact was conducted during daylight hours over 3 to 4 kilometers against approximately eight target arrays consisting of approximately 70 targets total and culminated in a hasty attack against a defended enemy cache (squad size). The ambush was conducted during the hours of darkness against a vehicular convoy containing light armored vehicles as well as dismounted targets and a reaction force. The attack was conducted during daylight hours with a platoon acting as the assault element of a notional company and conducting a breach of a wire/mine obstacle, seizing a foothold to the trench line, clearing trenches, and knocking out bunkers.

Platoon strengths during these operations varied but generally enough soldiers were present to allow the unit to plan and issue orders, move while not in contact, navigate, disseminate information, and react to indirect fires. Areas that needed improvement were rehearsals, movement techniques on enemy contact, infantry use of demolitions, weapons discipline (muzzle orientation and accidental discharge), night marksmanship, control and distribution of fires, direct fire suppression, and basic execution of battle drills.

The following paragraphs highlight some of the areas noted above from lessons learned during the past several rotations.

E-1. MOVEMENT TECHNIQUES

Appropriate movement techniques were used at the start based on the terrain and enemy situation. However, speed was costly. Squads often moved too quickly, failing to sight the enemy targets when they were within viewing range thus allowing the enemy targets to engage first, pinning down the lead squad and resulting in casualties. Once pinned

down, the thick vegetation prevented teams and squads from being able to locate, identify, and suppress enemy targets. The traveling overwatch formation was the movement technique normally used at the start and was acceptable based on the threat. However, after initial contact had been made, platoons failed to adjust the movement technique. Platoons continued to use traveling overwatch despite the number of subsequent contacts. Platoons were particularly strong in controlling movement *when not in contact* and made good use of arm-and-hand signals to communicate back and forth.

E-2. DIRECT FIRE SUPPRESSION

Platoons failed to understand the importance of direct fire suppression. Units failed to achieve direct fire suppression or gain fire superiority regardless of where the contact occurred (for example, engagement on movement to contact, supporting the breach effort during the assault on a fortified position, or ambushing a vehicular convoy). Point elements often did not fire when they spotted the enemy first. Instead, they hesitated waiting for guidance. Even when fired on first, there was a hesitation to fire and when fire was returned, it was normally sporadic and not well controlled. While volume and rate of fire was important, sound was often mistaken for suppressive fire without regard to its effect (being accurately placed in known or suspected enemy locations). Platoons were slow in putting machine guns in action. Usually this was the result of them not being under the direct positive control of the platoon leader, platoon sergeant, or one of the squad leaders. Leaders who kept the guns under positive control and well forward usually were effective in putting them in action and influencing the outcome of the contact. However, this was the exception. Additionally, the machine guns were not positioned to their advantage due to the inability of junior leaders to quickly read the terrain. Machine guns were more effective when tripods and traverse and elevation mechanisms were used covering areas and locking in fires. Tripods have normally been used in the ambush and the attack (during support to the breach and assault), however, units routinely failed to use the tripods during engagements on the movement to contact.

E-3. MARKSMANSHIP

Individual marksmanship during daylight operations was good when soldiers took well-aimed shots. The majority of the targets hit were killed with head or chest shots. Junior leaders failed to use fire commands or other signals in controlling and distribution their fires. Soldiers continued to fire too high at night. Platoons failed to use good night marksmanship techniques such as elevation/aiming stakes, pyrotechnics, illumination, and NODs to lower firing trajectories.

E-4. WEAPONS DISCIPLINE

Weapons were generally well maintained. However, discipline concerning muzzle orientation was poor. Regardless of their location (assembly area, moving, or in contact), soldiers were not fully conscious of where their weapons were pointing and few on the spot corrections were being made by leaders. Several accidental discharges have occurred during these LFXs due to incorrect handling of weapons, failure to move with the weapon on safe, and complacency on the part of some soldiers to monitor their weapon's status. While fortunately no one was injured, this type performance is inexcusable and cannot go unchecked. The immediate chain of command in these incidents addressed the responsible soldiers. In future exercises, individuals will be pulled and reported to the brigade chain of command. Problems have also been noted with the handling and accountability of hand grenades. To date, training indicates that soldiers are uneasy when issued grenades to carry as part of their basic load. Several grenades were dropped as soldiers moved through an event due to failure to attach the grenades correctly to webbing, lack of periodic personal checks for sensitive items (patting self down after a move/rush), and lack of leaders to periodically check.

E-5. BATTLE DRILLS

Battle drills were not executed to standard. Fire-team and squad leaders often demonstrated little initiative during contacts. Instead, they waited for the platoon leader to move forward and assess the situation before executing some form of maneuver or conducting fire and movement. When fire was returned, units neglected to lay down an adequate base of fire and gain fire superiority before attempting to assault. Units failed to appreciate the principle that maximum and effective aimed fire power must cover advancing troops. When elements got bogged down in the thick vegetation, they were unable to maintain visual contact between fire teams and squads, which limited the squad and platoon leaders' ability to properly assess the situation. This led to the execution of platoon battle drills when most of the time one squad had sufficient fire power and means to deal with the engagement. Platoons/squads failed to assault all the way across objectives. Once contact has been made, until the area from which it originated has been physically secured, it must be treated as though it is occupied by hostile personnel. An absence of fire does not mean the area is secure. Squads must use fire and movement, either by teams or individuals, all the way across limiting their exposure to hostile fire. Soldiers are somewhat reluctant to use good individual movement techniques. Some of this may be attributed to the rocky conditions of the terrain and soil. It has been noted that soldiers wearing elbow and knee pads were much more aggressive and performed better IMT. Additionally,

soldiers often choose to use 3- to 5-second rushes in relatively open terrain with waist-high grass, whereas, choosing to high crawl would have afforded them some concealment. A number of the weaknesses noted here could be alleviated through the conduct of more thorough rehearsals. The majority of units do not want to spend enough time rehearsing actions on enemy contact, actions on the objective, and so forth, instead trying to focus a disproportionate amount of time on movement.

E-6. DEMOLITIONS

Basic demolitions tasks are weak within many of the infantry platoons. Soldiers are unfamiliar with the materials and handling of demolitions items such as C4 blocks, electrical/non-electrical blasting caps, time fuse, detonation cord, fuse igniters, crimpers, and so forth. Soldiers indicate a lack of knowledge with regard to the procedures involved in the basic preparation of electric and/or non-electric charges. They are unfamiliar with steps such as inspecting blasting caps, crimping caps, computing burn time, and so forth. Many can remember doing it at one point in time during their training (not necessarily with present unit) but their recall in performing specific tasks is vague.

APPENDIX F

MISSION-BASED AMMUNITION REQUIREMENTS

Ammunition usage and type for each mission varies from unit to unit. Variables such as the number of soldiers participating, the type of weapon systems used, and the type of mission being conducted account for units forecasting and using more or less ammunition. Each mission has unique ammunition requirements. STRAC should be used as a resource base and guideline. Historical data within the unit also helps determine ammunition requirements by showing the type of ammunition and the quantity expended the last time the same range or maneuver box was used. This will also assist the unit in forecasting ammunition for upcoming training events. The number of targets or engagements on a live-fire range will also determine the amount of ammunition needed. Units should maintain records of ammunition usage on each weapon system for future use.

Figure F-1, page F-2 shows examples of ammunition requirements for three platoon LFXs: movement to contact/hasty attack, ambush, and attack. (These are based on JRTC data.) Ammunition breakdown is included for each mission. These ammunition requirements are based on basic loads per individual/weapon, number of individuals/weapons per light rifle platoon, STRAC, and ARTEP 7-20. These examples will help in forecasting and projecting the ammunition requirements needed for live-fire training. (Blank ammunition requirements must also be projected for rehearsals.)

DODIC	NOUN NOMENCLATURE	AMBUSH	MOVEMENT TO CONTACT/HASTY ATTACK	ATTACK	TOTAL
A059	M16A1 5.56-MM BALL	1248	1248	1248	3744
A063	M16A1 5.56-MM TRACER	312	312	312	936
*A011	M1200 00B BUCKSHOT	20	20	20	60
A064	M249 5.56-MM LINKED	3600	3600	3600	10800
A131	M60 7.62-MM LINKED	1600	1600	1600	4800
*A363	M9 9-MM BALL	100	100	100	300
B519	M203 40-MM PRAC M385	30	60	60	150
B477	M203 40-MM SMK M680	0	18	18	36
B535	M203 40-MM ILLUM	12	0	0	12
G881	M67 GREN HAND FRAG	0	70	70	140
+M557	M72A2 LAW HEAT	0	6	6	12
H708	M72A2 SUBCAL M73 W/M190 LAUNCHER	4	0	0	4
+C995	M136 AT4 HEAT	0	6	6	12
A358	M136 SUBCAL M939 W/M287 LAUNCHER	4	0	0	4
*PL22	M47 DRAGON INERT	2	0	0	2
*C410	M67 90-MM CANISTER 590	0	2	2	4
*C282	M67 90-MM HEAT M371	0	2	2	4
*A131	M67 90-MM SUBCAL 7.62-MM W/M49A1 SUBCAL DEVICE	2	0	0	2
*XXXX	M3-550 84-MM HEAT, ILLUM, SMK				
*H110	M202 INCEND M74 RKT 66-MM	0	0	2	2
K143	M18A1 MINE AP	6	0	0	6
M028	DEMO KIT BANGALORE	0	0	2	2
B643	M224 60-MM HE	12	12	12	36
*B627	M224 60-MM ILLUM	12	0	0	12
C236	M29A1 81-MM HE	12	0	30	42
N334	FUZE PD 81-MM	12	0	30	42
*C226	M29A1 81-MM ILLUM	12	0	0	12
C445	M102 105-MM HE	0	0	40	40
N340	FUZE PD 105-MM	0	0	40	40
C479	M102 105-MM SMOKE	0	0	15	15
M023	CHG DEMO BLOCK C4	1	0	2	3
M670	FUZE BLASTING TIME (FT)	100	0	100	200
M456	CORD DETONATING	200	0	200	400
M131	BLASTING CAP NON ELEC	10	0	10	20
M766	IGNITER TIME FUZE M60	10	0	10	20
G930	HG SMOKE HC	5	10	10	25
G940	HG SMOKE GREEN	0	5	5	10
G955	HG SMOKE VIOLET	0	5	5	10
L307	SIG ILL WSC	2	2	2	6
L314	SIG ILL GSC	2	2	2	6
L495	TRIP FLARE SURFACE	2	0	0	2

* Optional use
+ Subcal munitions may be substituted

Figure F-1. Example of ammunition requirements (JRTC).

APPENDIX G

SURFACE DANGER ZONES AND SAFETY FANS

The governing regulation for SDZs and safety fans is AR 385-63. A thorough understanding of this Army Regulation is necessary. It and local policies should be used to execute LFXs. The information in this appendix provides a broad overview of SDZs and how they are used in LFXs. Because this is not a sole-source document, Army and installation procedures must be studied before conducting an LFX.

G-1. INTRODUCTION

Leaders must constantly stress muzzle orientation. Individuals must keep the muzzle of their weapon directed away from friendly troops and the weapon on safe when not firing or when moving (as in 3- to 5-second rushes).

a. Early in the planning phase of conducting an LFX, the leader should read and understand the applicable portions of AR 385-63. As a minimum, the following sections must be understood: paragraph 3-1, ammunition positioning and issuance; Chapter 4, Firing; Chapter 16, Live-Fire Exercises; and the applicable chapters and paragraphs for the specific weapons being used.

b. A key to receiving range control approval of the LFX plan is the creation of an accurate composite SDZ overlay. Adherence to the constraints of the SDZ, AR 385-63, and local SOPs are the best assurance of conducting a safe range. Early and continuous coordination with range control can greatly simplify the process of determining the SDZ and the safety requirements for the maneuver box or range.

G-2. MAKING A COMPOSITE SURFACE DANGER ZONE

A composite SDZ is an overlay of all the SDZs involved in a given exercise. It considers each type of weapon to be employed, the scheme of maneuver, and the relationships between each firing position and group of targets. It represents the worst case for each phase of the operation and is used to coordinate known constraints with realistic training. This process is a necessary step in detailed planning.

a. **Tools Required.** The following tools are required to make a composite SDZ:

(1) Topographical map of the area to be used. A scale of 1:25,000 is preferred, but 1:50,000 is acceptable.

- (2) AR 385-63.
- (3) Protractor.
- (4) Straight edge.
- (5) Compass.

(6) Templates of SDZs for all weapons to be employed. These may be made using clear acetate, straight edge, compass, protractor, and the data in AR 385-63 (Figures G-1 and G-2).

b. **Outline Plan.** The outline plan is the initial concept of maneuver as applied to the proposed training area. This is usually the first step in determining the composite surface danger zone. The basic information required includes: the list of all weapons to be fired, a concept of what the target array must represent in terms of an OPFOR scenario (available from the battalion S2) and a general idea of the SDZ dimensions. A ground reconnaissance would be helpful to verify suitable firing points and engagement areas. An initial cross-check with the map will enable you to estimate whether the SDZs will violate established constraints.

c. **Direct Fire.** After developing the outline plan, diagram the surface danger zones for each direct-fire weapon system to be used.

(1) **Step 1.** Beginning at the first set of firing positions (FP), determine the realistic boundary for each platoon and the target areas to be engaged from that position. Using the SDZ template(s) for all weapons to be fired from that position, diagram the SDZ—

- From the farthest left FP to the farthest right target; that is, farthest left in the target area.
- From the farthest right FP to the farthest right target.
- From the farthest left FP to the farthest left target.
- From the farthest right FP to the farthest left target.

Verify that the overall outline contains the SDZ from likely FPs within the position by double-checking with the template. Also verify that the resulting crossfire SDZs do not overlap other FPs within the platoon position, creating an unacceptable risk.

(2) **Step 2.** Repeat the process for each set of positions throughout the scenario. Consider not only the target areas that you expect to engage from each position, but also the other areas that can be safely engaged.

(3) **Step 3.** War-game the battle considering likely contingencies, and determine the appropriate actions. For example:

CONDITION	RESPONSE
Platoon departs from expected axis and drifts toward the gun-target line of the overwatch element.	<ol style="list-style-type: none"> 1. Interrupt established target sequence. 2. Present alternate target farther away from maneuver element. 3. Ensure that the platoon leader is aware of the situation and issues a corrective FRAGO.
Platoon oriented on incorrect (unsafe) target area.	<ol style="list-style-type: none"> 1. Present the platoon's prescribed target before presenting targets in the incorrect area, so the platoon will reorient and engage the correct target.

(4) **Step 4.** Develop operational control measures such as axis, lateral boundaries, TRPs, engagement areas, and phase lines along identifiable terrain to support the SDZs (safe-sided).

d. **Indirect Fire.** In conjunction with the FIST, establish a fire support plan that supports the scheme of maneuver. Targets are placed in groups.

(1) **Step 1.** Determine firing points to be used and match FPs to target groups.

(2) **Step 2.** Diagram each set of FPs and targets. Make sure the diagram accounts for nonstandard firing points if the firing unit is dispersed from established (surveyed) FPs.

(3) **Step 3.** Develop contingent SDZs for FP targets not originally programmed. This will help determine what constraints exist.

(4) **Step 4.** Compare indirect fire with the scheme of maneuver and direct fire SDZs to determine—

- When fires must be shifted.
- When supporting elements must move.
- Whether direct fire SDZs overlap onto indirect-firing points.

(5) **Step 5.** Establish maneuver and fire control measures, and express the information developed in operational terms and or graphics. One of the most critical elements is the control of scheduled fires. Generally, preparatory fires before (and while) the unit crosses the LD are not a problem. A positive check must be made to ensure all vehicles and personnel are clear of the SDZ if they will occupy positions in the SDZ during the exercise. For example, a mortar platoon that occupies a position forward of the initial firing line after the firing line has moved.

G-3. FLANK MANEUVER LIVE-FIRE EXERCISES

Flank maneuver LFXs are LFXs making maximum use of flanking fires to engage enemy positions. Flank maneuver LFXs are set up and conducted IAW AR 385-63 and are not new; they are, however, the preferred technique for conducting the LFX. By using flank maneuver LFXs, maneuver units receive the maximum benefit of close direct fire support while attacking the vulnerable flank of the enemy objective.

a. Flank maneuver LFXs take maximum advantage of the SDZ in achieving flanking fire on the objective. IAW AR 385-63, paragraph 16-4 1., all weapons may be used to provide flanking fire. Specifically, small arms may be fired near the flank of the maneuver unit. When firing near the flank of the maneuver unit, there must be at least an angle of 15 degrees between the limit of fire and the closest individual, all firing must be conducted at low elevations, and all rounds must impact beyond the maneuver unit. Additionally, traversing and depression stops will be provided on machine guns to ensure that the minimum 15 degree angle is maintained.

b. When conducting flank maneuver LFXs, the supporting unit must know the location of the maneuver unit in order to ensure that no unprotected personnel are within their sector of fire. Checkpoints, phase lines, or other control measures are usually adequate, but in extremely vegetated terrain, visual marking of lead and flanking personnel may be required. Flags tied to the antennas of safety personnel or safety personnel wearing road guard vests will usually suffice in adequately marking the flanking unit's location. Marking personnel undergoing the LFX should be avoided as it detracts from realism.

c. When setting up a flank maneuver LFX, the route and location of maneuver units and the location of those weapons providing supporting fire must be described in detail. Natural terrain features or other identifiable means may be used.

G-4. WAIVERS

Paragraph 1-6, AR 385-63 authorizes major Army commanders to waive safety criteria contained in AR 385-63 if waivers result in acceptable safe conditions and are in the best interest of the United States. Waiver authority is delegated to general officers commanding TRADOC installations. No further delegation is permitted and must be limited to the following criteria.

a. The dimensions of SDZs as described in AR 385-63 maybe reduced when terrain, artificial barriers, or other controlling factors make smaller areas safe.

b. Prescribed firing procedures appropriate for training of participating troops may be modified to increase realism in training, provided safety of personnel is not degraded.

G-5. INFORMATION FOR RANGE CONTROL

In planning for an LFX, range control will normally require the following information:

- A detailed scenario with sketches/overlays that define the scheme of maneuver and the integration of supporting fires.
- Coordination lines or checkpoints to identify maneuver limits.
- Limits of fire for each element and/or weapon (SDZ).
- Mortar/artillery firing data, safety cards, shift information.
- Specific controls for firing while moving.
- Provisions for search, marking, and disposal of duds.
- Communication and control measures to include air observer if employed.
- Safety checklist.
- Target system support.
- Waiver justifications (if required).

APPENDIX H

OBSERVER-CONTROLLER INFORMATION

OCs act as the commander's principle trainers, provide tactical realism, and supplement the unit's safety program. They may be used to evaluate any level of training and are most effective when used to observe-control small groups of soldiers. The level of feedback desired will be determined by the exercise commander and or his staff OCs should work with, and for, the company and battalion commanders. This appendix provides a guide to establish the minimum essential information needed to perform as an OC. (See the appropriate ARTEP MTP for additional OC information.)

H-1. PERFORMANCE STANDARDS

All OCs should perform to the following performance standards:

- Always use common sense and good judgement.
- Know, understand, and enforce the exercise commander's guidance. When in doubt, check with higher.
- Be an expert in the field, and doctrinally correct.
- Know the safety standards and enforce them; protecting the force is paramount.
- Be a MILES expert and enforce MILES procedures.
- Prepare and assist with AARs that are professional and doctrinally correct.
- Use and reinforce the unit chain of command.
- Take control when safety violations occur or when life, limb, or eyesight are threatened.
- Go where the action is.
- Control LFX target exposures, and record results.
- Discuss individual and unit performance on a need-to-know basis only.
- Maintain high standards of personal appearance and conduct.

H-2. FUNCTIONS

OCs are the eyes and the ears of the exercise commander as well as the primary trainer. The unit chain of command, while responsible for safety

and training, cannot focus attention on these areas during a combat exercise—their concern may be maneuver, calling for fire, or evacuating casualties. OC functions may include the following as well as any additional instructions provided within the commander's guidance.

a. **Observing and Controlling Training.** This does not mean lead the unit; it refers to ensuring that the unit understands the tactical scenario and executes its missions within doctrinally correct parameters. Assessing casualties and reporting unit activities are other important aspects of control. OC duties require the OC to be where the action is to ensure the feedback provided during AARs is beneficial and accurate. However, the OC's actions should not compromise the unit's game plan.

b. **Setting the Example.** The controller should wear the same uniform, camouflage, and equipment as the unit conducting training. When possible, he should also move as the unit moves (for example, kneel, assume the prone position, and so forth).

c. **Teaching and Coaching.** Knowledge of the unit, enemy doctrine, and tactical scenario is expected. OCs must also understand the major points of emphasis the commander is teaching and the results the commander expects. However, OCs must not instruct or lead counterparts into doing what they (OCs) think should be done. OCs should ask leading questions to ensure counterparts understand the operational plan and achieve results through the proper implementation of doctrine. OCs must also tailor coaching to the level of the unit's training.

d. **Providing Feedback and Assisting with AARs.** A major responsibility of an OC is enunciated in the duty description, OBSERVE. The observations of the OC provide feedback to the maneuver unit(s) during the AAR so observations should be recorded. Although soldiers and leaders provide valuable feedback, input from an outside observer is important to a quality AAR.

e. **Assessing Casualties.** Assessing casualties is critical for replicating battlefield conditions. Exercise commanders will provide specific tables for kill ratios according to the varying combat multipliers available and used by friendly forces or OPFOR. The following procedures provide general guidance for most casualty assessments:

(1) The OC is alerted to contact. Usually the OC will hear shots or explosions, be alerted over the radio, or see contact develop.

(2) The OC alerts the appropriate agency that a contact is in progress.

(3) The OC uses casualty ratio tables (kill cards) to assess casualties in long-range engagements, indirect fire engagement, CAS engagements, and other engagements as appropriate.

(4) The OC supports/supplements ineffective and inoperable MILES equipment. Although MILES is the most effective means of assessing force-on-force engagements, at times it must be supplemented due to

environmental and/or resource constraints. The OC must be aware of the various constraints and apply this to casualty ratios. When doctrine is obviously being violated, the OC may assess casualties through the use of the controller's gun. Remember, the controller's gun is an instruction tool and should be used judiciously.

(5) The OC instructs MILES casualties to sit down where their MILES went off, place the yellow weapons key in their harness, stay quiet, and remove headgear. If soldiers are carrying casualty cards, the OC should fill in casualty information as soon as possible. Casualty information will instruct the soldiers as to the nature of their wounds and what they can and cannot do and/or say.

(6) The OC reports casualties (type and number) to appropriate agency.

(7) The OC monitors casualty treatment and evacuation procedures. This is important to supply feedback during the AAR.

f. **Controlling Targetry.** When remote targets can be used in an LFX, one OC should be designated as the primary controller and a second should be designated as an alternate. These controllers should be with the lead elements. By setting up multiple target arrays, the OC can influence the movement of a unit to maintain a safe, tactically realistic scenario.

g. **Reporting.** All OCs must report unit activities to ensure higher headquarters is kept informed and current on the ground situation. In general, a report should be made whenever the situation changes. The exercise commander or his representative should provide reporting formats. The following events demand an immediate response:

- Any contact and casualties from contact.
- Any fratricide.
- Use of chemical agents by either force.
- Troop/unit movements.

H-3. PROTECT THE FORCE

Realism in force-on-force and live-fire engagements is never an excuse for an unsafe act. OCs should supplement and enforce the commander's safety program. Every soldier is a safety, and protection of the force precludes any other action.

H-4. CONTROLLER-TO-SOLDIER RATIO

For LFXs, each squad should have one controller. Force-on-force exercises need one controller for each squad or at least one for each platoon. For the best results in gathering information, one for each squad is recommended.

H-5. AFTER-ACTION REVIEWS

All controllers must be trained in AAR techniques and be prepared to conduct AARs with subgroups. The chief controller should debrief all controllers and assistants before the AARs.

a. Controllers should not critique or lecture. They should guide the discussions by asking leading questions. They should enter the discussion only to sustain the AAR, to get the discussion back on the right track, or to bring out new points.

b. The following techniques make the AAR an effective part of training:

- Emphasize the positive; do not embarrass leaders or soldiers.
- Have participants describe what happened in their own terms.
- Outline and prepare the discussions and then rehearse them.
- Prepare thought-provoking questions to stimulate discussion.
- Relate tactical events to subsequent results and training objectives.
- Ensure that alternate courses of action are discussed.
- Avoid discussion of minor events that do not directly relate to the major training objectives.
- Use terrain models and training aids to illustrate events. Have participants relate comments to the model and move the markers for units, vehicles, and personnel to show events. Playbacks of key events will generate interest and discussions.
- Ensure every element that participated in the exercise is present at the AAR.
- Ensure training deficiencies that surface during the AAR are incorporated into the unit training schedule within two to six weeks after the exercise.

c. An AAR for an exercise might follow the following format: (See appropriate ARTEP MTP for more detailed information.)

- Statement of training objectives.
- Statement of the commander's concept.
- Narration of events before contact.
 - Assembly area.
 - Planning.
 - Preparation.
- Discussion of events (initial engagement to termination of exercise).
 - Key events.
 - Actions and reports.
 - Results.
 - Alternatives.
- Summary.

APPENDIX I

FIRE CONTROL

Fire control consists of fire control measures and fire commands. Fire control allows a unit to select targets, initiate fires at desired instant, adjust fire, control rate of fire, and halt fire.

- *Fire control measures control the distribution of fires. Some fire control measures include sectors of fire, priority target engagement, and target reference points. They must be simple and clearly understood. Their use must be routine, without the need for detailed or lengthy instructions. Fire control measures should exist at all times (during movement, halts, actions on the objective, and so on). Some simple measures that can be used to effectively distribute and control fires are described in this appendix.*
- *Fire commands execute the control measures desired. They can take the form of oral commands, arm-and-hand signals, visual and sound signals, personal contact, or SOP.*

I-1. TERRAIN-ORIENTED TECHNIQUES

Three primary techniques orient the weapon or unit to the terrain for which they are responsible. These are sectors of fire, engagement areas, and target reference points. Phase lines, a fourth terrain-oriented technique, can supplement the other three. Almost any movement control measure can be used to control fires. This includes restrictive fire areas (RFAs) and restrictive fire lines (RFLs).

a. **Sector of Fire.** Each sector of fire is a specific area, limited by boundaries, that is assigned to a unit or individual weapon system to cover by observation and fire. A sector of fire is designated by pointing out easily recognizable terrain features such as roads, streams, hills, or ridge lines that outline the sector. It is most often designated by left and right limits and can extend out from a firing position to the maximum engagement range of the weapons. It can be an enclosed area with near and far limits located a distance from the firing position. Also, the enclosed area can be designated an engagement area. If a weapon is assigned an enclosed sector or engagement area, the terrain between the sector of fire and the firing position may need to be covered by other weapons.

(1) In most situations, the terrain and the number and type of weapons available to cover an area will dictate how sectors of fire are assigned. They should be assigned so that an area is completely covered with the appropriate type of fire and that mutual support is established between each weapon or unit. To gain mutual support, each element normally is assigned a primary and a secondary sector of fire. The secondary sector of fire should correspond to another element's primary sector of fire.

(2) A sector of fire is not meant to restrict fires. Fire is shifted to the secondary sector on order, when there are no targets in the primary sector, or to cover another element if it is forced to move.

(3) If concentrating the fires of several weapons in a critical area such as a choke point is desired, overlapping sectors of fire can be assigned. This increases the problem of fire control and target overkill. Control measures such as TRPs, engagement priorities, fire patterns, and nearest-half/farthest-half techniques are needed. Leaders must select positions that allow them to observe and coordinate the fire. Different operations should plan sectors of fire on the objective based on SOPs or on the intelligence available. This is an appropriate measure to use in assignment of terrain features from a thorough map reconnaissance up to specific building assignments from an extensive site reconnaissance. Leaders must plan fires through consolidation and reorganization on the objective because the momentum will shift back to the defense.

b. Engagement Areas. An engagement area is an enclosed area or sector used to mass the fires of weapons. Engagement areas are common to antiarmor fire planning. They are usually designated by left, right, near, and far limits with clearly definable boundaries, and can be located a distance from friendly firing positions. They can also be designated by TRPs. Engagement areas can further be defined by sectors of fire or TRPs within the engagement area. Engagement areas are like sectors of fire, but are used as a tool to concentrate fires. Because the fires of many weapons may be massed into an engagement area, additional fire distribution techniques are necessary. One or more of the other fire techniques can be used for this purpose. Engagement areas can be identified by either numbers or names.

c. Target Reference Points. A TRP is an easily recognizable point on the ground (either natural or man-made) used as a reference point for identifying enemy targets and for controlling indirect fires. TRPs can be used to designate targets for company teams, platoons, sections, and individual weapons. They can also designate the center of an engagement area or the limits of a sector of fire. Once designated, TRPs also constitute indirect fire targets.

(1) TRPs are usually designated by company team commanders or platoon leaders. The task force commander may also designate TRPs in

order to mass the fires of company teams. TRPs should be planned on likely avenues of approach when defending and in likely enemy locations during offensive operations. Because weapons will be engaging from different directions, cardinal directions (north, south, east, west) are used rather than right or left when giving directions centered on a TRP.

(2) TRPs are designated using the standard target symbol and target numbers issued by the FIST or FSO. The symbol is a blank cross centered on the TRP location. The target numbers consist of two letters and four numbers. These identification numbers are recorded on range cards and sector sketches for easy reference and coordination. To simplify fire commands, TRPs may be referred to by the last three digits. For example, TRP AB5010 may be referred to as TRP 010.

d. Phase Lines. A phase line is a linear control measure that is normally used to control movement, but it can also be used to control and distribute the fire of several widely separated elements or weapons. Any natural or man-made linear terrain feature that is easy to identify can be used as a phase line; for example, a ridge line, river or stream, road, or railroad track. (Terrain features must be easily identifiable for phase lines to be effective as linear control measures.)

(1) In either offensive or defensive operations, phase lines can be used to simultaneously start or stop firing, shift fire to another sector, or indicate when elements or weapons are to move to alternate or supplementary positions. Phase lines can also be used to specify when target priorities are to change. For example, "I want all squads to engage only tanks with your Dragons until the enemy reaches Phase Line Silver. When the enemy crosses Silver, I want you to begin engaging BMPs with your Dragons."

(2) Phase lines can also be designated as fire-at-will lines for the control of small-arms fire. When the enemy attacks, small-arms fire can be held until he comes within rifle range (300 meters), or when he reaches a spot on the ground such as a road, open area, or a stream bank designated as a fire-at-will line. This control method allows the most effective fire because it will surprise the attacking troops and mass fire on them when they are in a disadvantageous position and formation. As the enemy moves closer, the volume and rate of fire must stop the attack before it reaches the platoon's position.

(3) In addition to being a simple and effective control measure, phase lines can be assigned as an emergency control measure if radio communications are interrupted by enemy jamming.

I-2. TARGET-ORIENTED TECHNIQUES

Three target-oriented techniques complement the primary terrain-oriented techniques. These are nearest-half/farthest-half, fire patterns, and engagement priorities. Once a friendly unit has been

oriented to the terrain using one or more of the primary techniques, these three techniques, used individually or together, distribute fire on an enemy formation (or target), thereby preventing overkill and ensuring complete coverage of the target.

a. **Nearest-Half/Farthest-Half Technique.** This is a method for rapid distribution of initial fire. Using the nearest-half technique, the element leader estimates how much of a target area can be seen and then directs his fires into that half of the target area nearest his element. An alternative to this technique is the farthest-half technique. Each element leader directs his fires into the half of the target farthest from his unit. This technique can be used to achieve oblique shots against a target. These techniques will not prevent an overkill on targets that appear to be in each element's half, but it does coordinate the initial volley. Within his half of the target area, the element leader distributes his fires using variations of fire patterns.

b. **Fire Patterns.** Three basic fire patterns can be used to distribute the platoon's or section's fire when multiple targets appear in a sector, an engagement area, or at a TRP. These are frontal fire, cross fire, and depth fire. Fire patterns are changed or used concurrently with another fire pattern when necessary to ensure maximum coverage of an enemy formation. This may be necessary when the enemy adjusts his formation after being engaged.

(1) Frontal fire is used when targets are dispersed laterally in relation to the platoon's direction of fire (Figure I-1). Initially, each weapon fires to its front with flank weapons engaging flank targets first. As targets are destroyed, fire is shifted toward the center of the enemy formation. This fire pattern is most effective when the enemy is not only dispersed laterally but is also moving laterally across the sector of fire. It is least effective when the enemy is moving directly toward the firing weapons, because the enemy's observation, firepower, and frontal (or thickest) armor are oriented toward the firing weapons. Frontal fire is least effective in the offense, due to the same concept of moving into the jaws of the enemy.

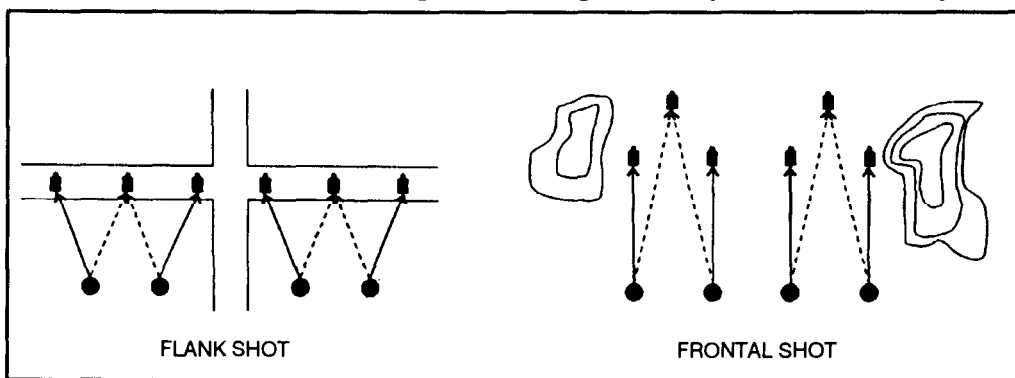

Figure I-1. Examples of frontal fire patterns.

(2) Cross fire is used either when targets are dispersed laterally and obstructions prevent all weapons from firing to the front, or when flank shots can be achieved from positions with frontal defilade (Figure I-2). Fire should be directed at the flank to increase the chance of a kill and to avoid detection when the enemy is moving straight at the friendly unit. Each element engages a target on a diagonal to its position, with flank elements engaging targets on the opposite flank. As targets are destroyed, fire is shifted to the center of the enemy formation.

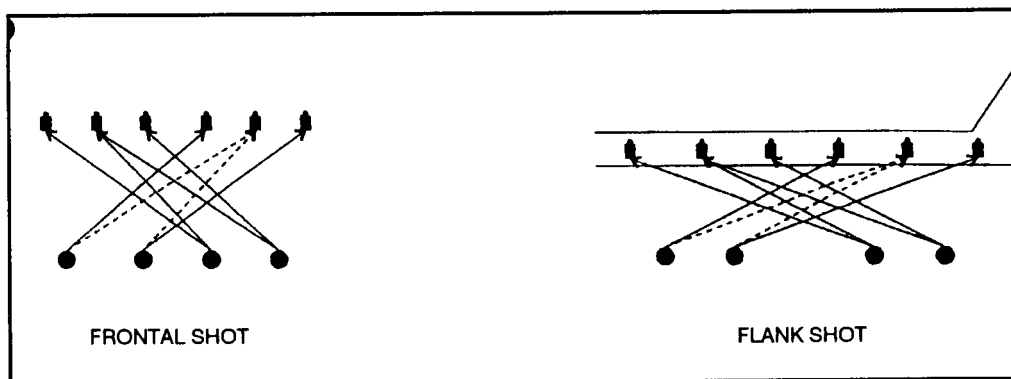

Figure I-2. Cross fire pattern.

(3) Depth fire is employed when targets are exposed in depth (Figure I-3). Weapons on one side engage the nearest targets, while weapons on the other side engage the farthest targets. Fire is then shifted toward the center of the formation. Unit SOP and the tactical situation will dictate which element is assigned the near targets and which element is assigned the deep targets.

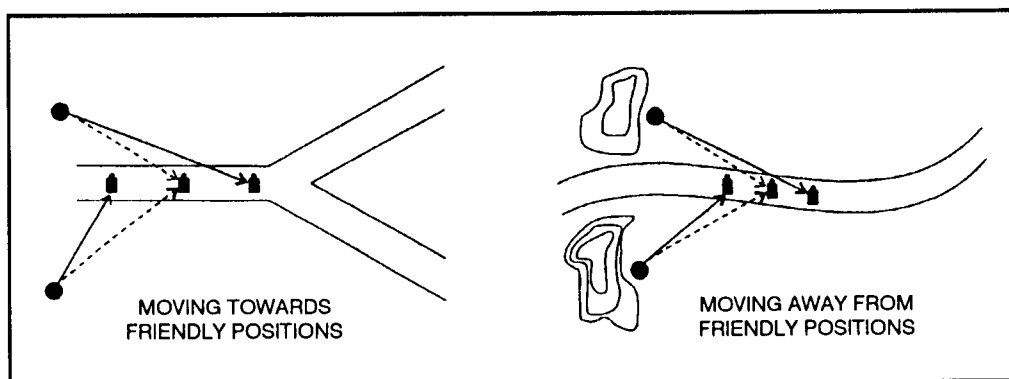

Figure I-3. Depth fire pattern.

c. **Engagement Priorities.** Usually targets appearing in formations on the battlefield will be of various types—tanks, BMPs, BRDMs, air defense vehicles, and so forth. Fire can be rapidly distributed and effectively controlled in such a situation by assigning each weapon or element a particular type of vehicle to engage initially. For example, "First squad

engage tanks. Second squad engage command vehicles. Third squad and headquarters engage BMPs." Another method is to assign each type friendly weapon system an enemy weapon system of the same type. For example, "Tanks kill tanks; TOWs kill BMPs." Of course, if a particular target is actually threatening a friendly weapon, that target must be engaged immediately, regardless of engagement priorities.

NOTE: When assigning engagement priorities, consideration should be given to destroying targets that present the greatest threat and targets that will break up the momentum of an attack such as command vehicles, mine-clearing vehicles, and bridging vehicles. It is also important to consider the ranges, armor protection, and lethality of the weapons involved to ensure that priorities reflect the ability of friendly weapons to destroy enemy targets.

I-3. FIRE CONTROL AND DISTRIBUTION PREPARATION

Most fire control and distribution measures are as viable in offensive operations as they are in defensive operations. Both require thorough preparation. This can be accomplished through rehearsals, individual training, unit training, and SOPs. (Figure I-4 shows examples of fire control and distribution.) Individual training should ensure that each soldier knows his area, technique, and limits of fire. Unit training should include instructions for specific weapons such as—

- M249 priorities.
- Antiarmor hunter/killer teams with thorough knowledge of priority vehicles.
- Security forces' primary/secondary missions.
- M203s—who carries, when/what they fire, marking techniques, and under supervision of leaders.
- M60 machine guns to include security and assistant gunner.
- Sniper priorities.
- Riflemen priorities.
- Mortars, artillery (primary targets, TRPs).

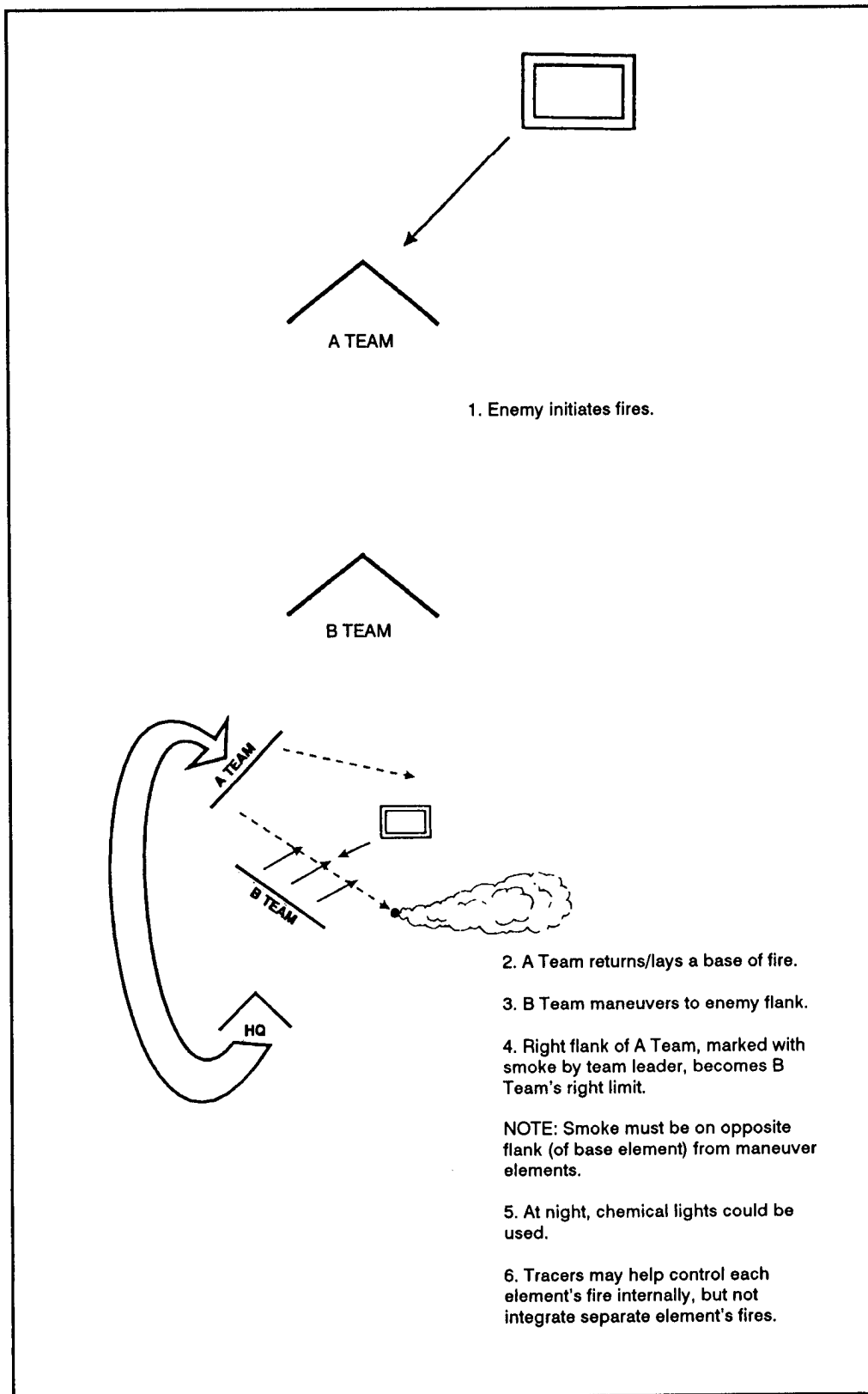

Figure I-4. Example of fire control and distribution.

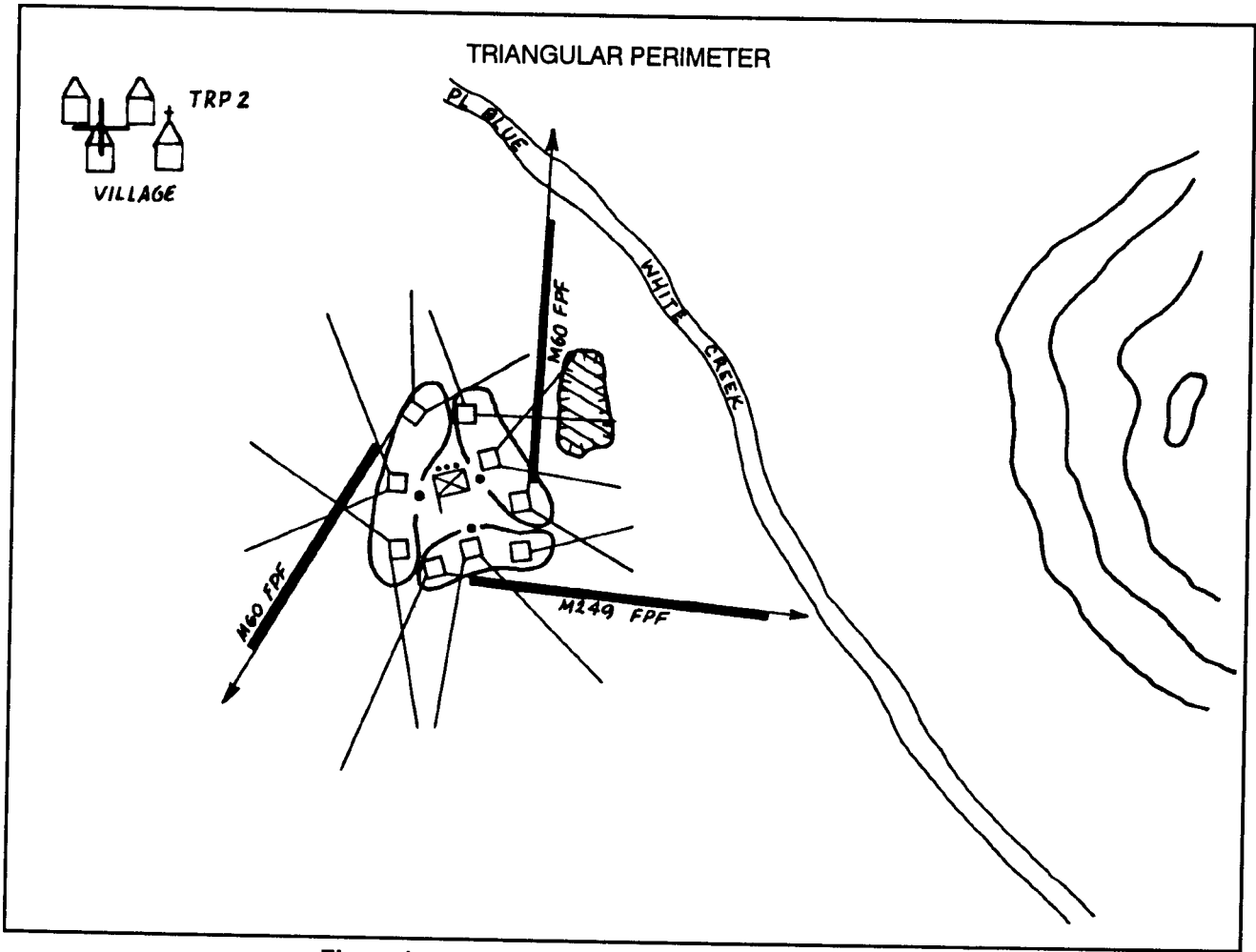

Figure I-4. Example of fire control and distribution (continued).

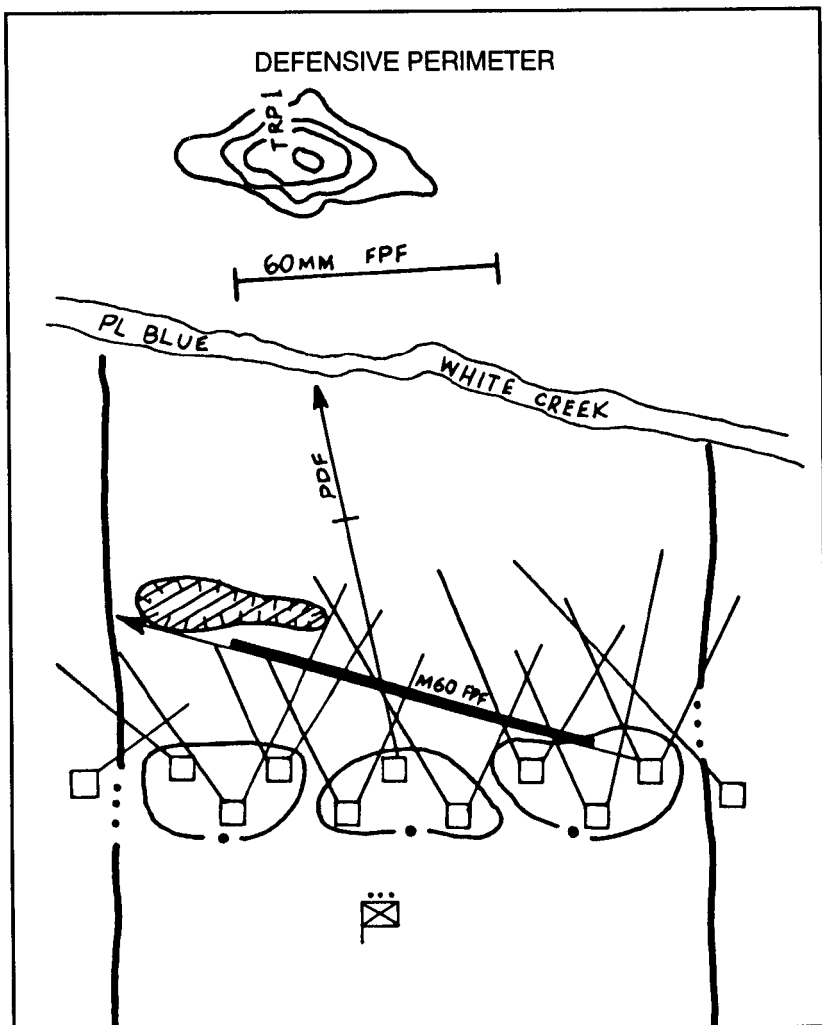
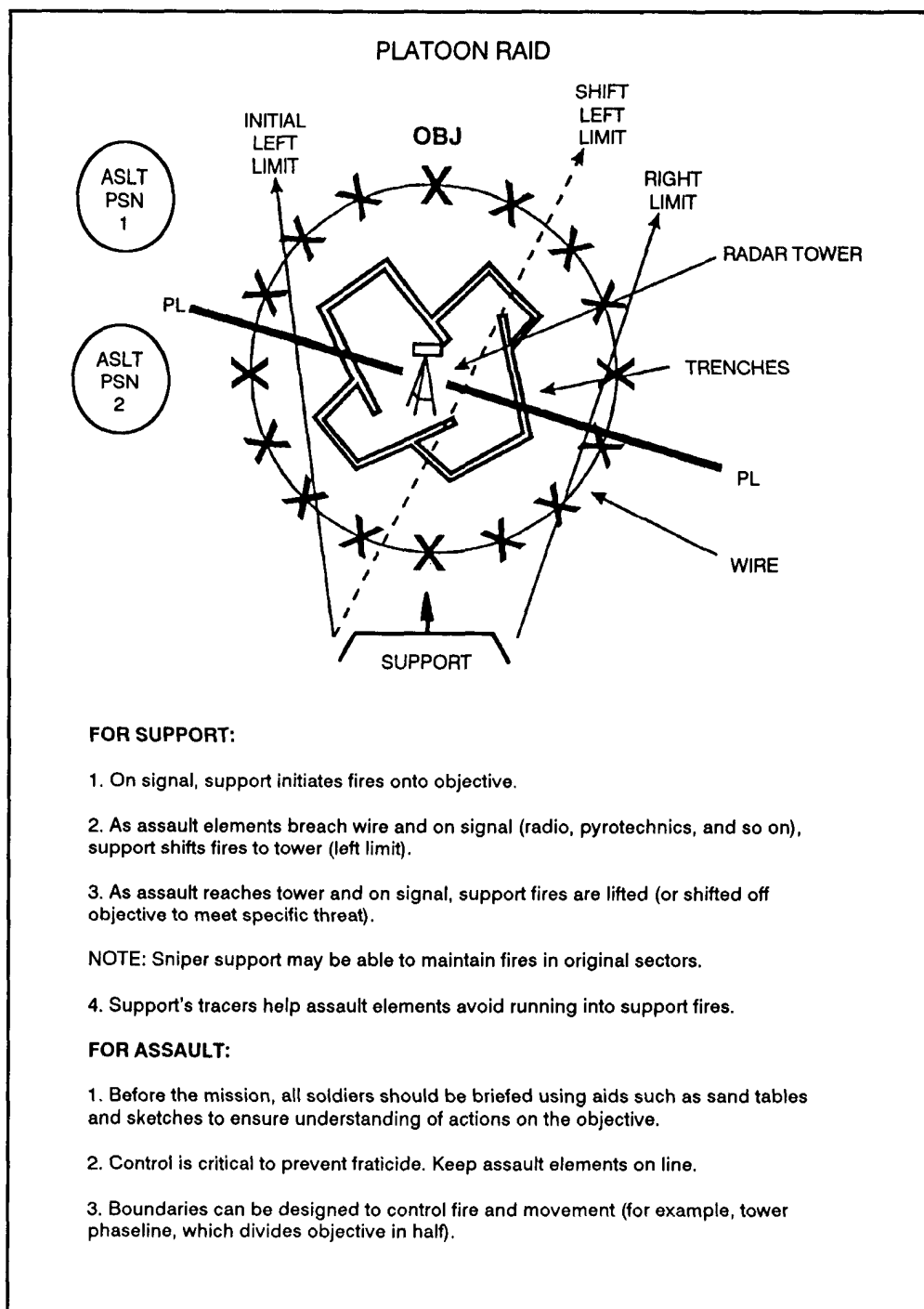

Figure I-4. Example of fire control and distribution (continued).



**Figure I-4. Example of fire control and distribution
(continued).**

APPENDIX J

LIVE-FIRE ASSESSMENT

When a unit conducts an LFX, the soldier gets a good look at the unit's command and control. Because of this, the command element must be trained before the LFX. While a TEWT is important, it may not be enough. A TEWT generally does not satisfactorily integrate the unit's weapon systems. A fire coordination exercise (FCX) can fill this void. (FM 25-4 discusses the different exercises available to the unit based on training objectives and resources.)

J-1. AREAS OF ASSESSMENT

During an LFX, everything done can be evaluated. Measuring all individual and collective tasks would be nearly impossible due to the magnitude of tasks performed on a daily basis. While no tasks should be completely ignored, selected tasks should be focused on. Since most tasks can be assessed without conducting an LFX, concentration should be on evaluating those areas that can best be measured within the context of an LFX. Some of these are—

- a. Reinforcement of principles of command and control within the context of an LFX. (See Chapter 2.) This includes fire commands, fire discipline, fire control measures (TRPs, FPFs, sectors of fire, and so on), indirect fire support, and base of fire (lifting and shifting fires).
- b. Weapon system integration using organic and nonorganic weapons (M16 rifle, M203 grenade launcher, M249, grenades, Claymore mines, AT4s, mortars, artillery, and so on).
- c. Target identification (including friendly forces), acquisition, and engagement (including suppression and fire distribution).
- d. Concentration on the use of maneuver, fires, and terrain simultaneously.
- e. Communications.

J-2. ASSESSMENT PROCESS

Units should use different manuals such as FM 7-8, FM 7-7, and ARTEP 7-8-MTP to assist in assessing their unit's proficiency at conducting live-fire training. By using the checklists found in ARTEP 7-8-MTP and incorporating those standards with SOPs and other doctrinal manuals, units should be able to assess live-fire training and establish their own

standards. (The checklist in Figure J-1 may also help.) These standards will change with different variables such as weather, terrain, ammunition availability, unit proficiency, and so on. Units might use competitions among squads, or other incentives, to increase the unit's ability to acquire and destroy targets with live ammunition. When assessing live-fire training, data should be kept in the unit's training files to help future training and build a data base at the unit level.

a. Maintaining a positive environment is important for learning. An assessment is not a critique. Therefore, empirical data should be used to merely assist in identifying strengths and weaknesses, not to pronounce pass or fail. The fact that variable conditions affect each LFX differently should be remembered when compiling data.

b. MTPs should be used as the primary source of assessments.

c. Field manuals also help the leader in assessing the unit. These FMs sometimes offer alternative concepts and ideas in an approach to a tactical problem. FMs also go into much more depth than an MTP, and can be used to help assess problem areas.

d. Marksmanship data helps the leader by pointing out potential problems. The example in Figure J-2 on page J-4 shows how marksmanship data can be used in the assessment process:

(1) Use of marksmanship data can be subjective. When using multiple weapon systems, the OC may not always be able to tell what type of projectile hit the target (hand grenade, AT4, M16 rounds, or M249 rounds). Therefore, this information should be evaluated and used carefully to identify general strengths and weaknesses. (See Table J-1 for an example of ammunition expended by a squad at personnel targets.)

(2) Using Table J-1, the deduction can be made that AT4 training is to standard, M16 training is adequate, and M60 training needs work. Varying conditions (day/night, NBC environment, precipitation, and so on) can make determining proficiency difficult. These variables should be discussed in the AAR. (See Chapter 2 for more information on live-fire variables). The unit will then know which training areas need improvement. For reference, all data may be written down. (Figure J-3 provides an example of how this data might be recorded.)

WEAPON	TOTAL HITS	AMMUNITION EXPENDED	HIT/EXPENDITURE RATIO
M16	41	122	1/3
AT4	2	2	1/1
M60	40	800	1/20
M203, HE	2	7	1/3.5

Table J-1. Example of ammunition expended.

FIRE PLANNING AND CONTROL MEASURES CHECKLIST

1. Were engagement criteria or engagement areas used?
2. What type of control measures were used?
 - Phase lines.
 - TRPs.
 - FPFs.
 - FPLs.
 - PDFs.
 - RFAs.
 - RFLs.
 - Other.
3. Were sectors of fire used?
4. Was priority of weapons employment specified? (M203, M16, M60, M249)
5. What initiated fires?
 - Oral command.
 - Battle drill.
 - Pre-established time.
 - Trigger point.
 - Other.
6. What types of firing techniques were used?
 - Simultaneous.
 - Alternating.
 - Observed.
 - Other.
7. What type fire pattern was used, if any?
 - Frontal fire.
 - Cross fire.
 - Depth fire.
 - Other.
8. Were fire commands used?
9. Were concise orders given throughout by leaders to subordinates?
10. Were fires shifted or lifted? If so, what type of techniques were used?
 - Oral signals.
 - Arm-and-hand signals.
 - Communications (wire, radio, and so on).
 - Pyrotechnics.
 - VS-17 panel.
 - Whistles.
11. During reorganization and consolidation, was the following accomplished?
 - Crew-served weapons emplaced.
 - Sectors of fire established.
 - Fire plan.
 - Sector sketch prepared.
 - Other priorities IAW unit SOP.

Figure J-1. Example fire planning and control measures checklist.

1. Identify target type and location.
 Three personnel (upper torso)
 bunker, hill 102..... TGT 09

 One moving armored car
 road, VC 123232..... TGT 11
2. Identify the number of hits and their location on the target (use diagrams).

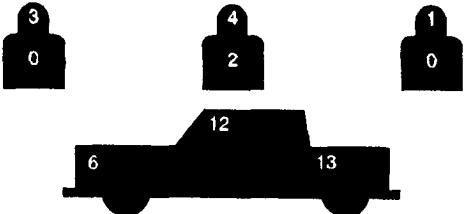
3. Identify total number of rounds expended. (Ensure all unused ammunition is collected and credited to the unit.)

 TOTAL HITS (M16) 41
 AMMUNITION EXPENDED (M16) 122
4. Present this data in the AAR for discussion and identification of reasons for the results.

Figure J-2. Example marksmanship data.

Mission: (MTC, ATK, AMB) Conditions: (NBC GEAR, SMOKE, NIGHT)		
Targets NUMBER/TYPE	HITS/RDS EXP	TARGET/HIT RATIO
Weapon System: M16		
42/personnel, static 02/personnel, moving SUBTOTAL	34 12 46/237	1/5.2
03/BMP	36/397	1/11
Weapon System: M60		
42/personnel, static 02/personnel, moving SUBTOTAL	13 01 14/131	1/9.4
03/BMP, moving	36/209	1/5.8

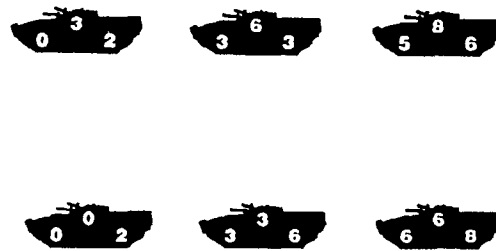

Figure J-3. Example marksmanship data collection sheet.

APPENDIX K

TRAINING AREAS AND RANGES

Military leaders must determine which tasks the unit needs to train. Each type and size unit has different training needs. Even like units will focus on training different task because of varying degrees of proficiency. The decision on what to train helps determine where to train a unit on live-fire skills.

This appendix discusses training various elements through LFXs using different types of Army ranges. (See FM 25-7 for additional information on training ranges.)

K-1. INTRODUCTION

The Army has many fixed live-fire ranges located on various installations. The optimum training area is one that provides feedback and realism (life-like targetry, freedom to maneuver; battle sounds, and so on). A maneuver box has the most potential to meet these requirements. However, a maneuver box may be difficult to obtain at different installations, and it takes a lot of time and effort to prepare. This paragraph discusses the maneuver box and some alternatives (the multipurpose range complex-light [MPRC-L] and the infantry platoon battle course [IPBC] or the infantry squad battle course [ISBC]) that require less effort to set up. (Table K-1 provides a comparison of the MPRC-L, IPBC, ISBC, and maneuver box.)

COURSE	STRENGTHS/CAPABILITIES	WEAKNESSES
MPRC-L	<ol style="list-style-type: none"> 1. Quick set up. <ol style="list-style-type: none"> a. SDZ and targetry are preset. b. Existing scenario. 2. Requires fewer O/Cs. 	<ol style="list-style-type: none"> 1. Nonflexible. <ol style="list-style-type: none"> a. Cannot change site location of targets. b. Missions limited.
IPBC or ISBC	<ol style="list-style-type: none"> 1. Quick set up. <ol style="list-style-type: none"> a. SDZ and targetry are preset. 2. Requires fewer O/Cs. 	<ol style="list-style-type: none"> 1. Nonflexible. <ol style="list-style-type: none"> a. Cannot change target or site location.
MANEUVER BOX	<ol style="list-style-type: none"> 1. Flexible. <ol style="list-style-type: none"> a. Allows selection of terrain, target, location. b. May encompass more and larger weapon systems. 2. More realistic. 	<ol style="list-style-type: none"> 1. Time consuming <ol style="list-style-type: none"> a. Must select site and target location. b. Must complete SDZs. c. Must develop scenario. 2. O/C intensive.

Table K-1. Comparison of MPRC-L, IPBC/ISBC, and maneuver box.

a. The maneuver box concept allows the subordinate leader to select the direction of approach to an objective (within his assigned sector). It gives him a sense of independence and freedom of action. It also heightens the seriousness of safety and control, and it is more realistic.

b. While the ultimate goal is to get the squad or platoon into a live-fire maneuver box to simulate realism, the unit may first want to participate in an LFX within a more controlled environment. This is critical if the leader determines that he wants to focus training on a limited number of collective live-fire tasks (for example, fire control measures or fire commands). The MPRC, the IPBC (Figure K-2 and the ISBC (Figure K-3, page K-5) provide a controlled environment for live-fire training. (See TC 25-8 for an example of an MPRC.) Even a standard range like the known-distance (KD) range can be used as a stepping stone to the maneuver box. Figure K-1 shows some of the different range training complexes found on various installations that can be used to train different size elements. (See FM 25-7 for more information.)

ELEMENT	RANGE				
BUDDY TEAM	FIRE-AND-MOVEMENT				
FIRE TEAM	KNOWN-DISTANCE	DEFENSE TEST			
SQUAD	KNOWN-DISTANCE	ISBC	MPRC	MANEUVER BOX	DEF TEST
PLATOON	KNOWN-DISTANCE	IPBC	MPRC	MANEUVER BOX	
COMPANY	MANEUVER BOX		MPRC		

Figure K-1. Range training complexes.

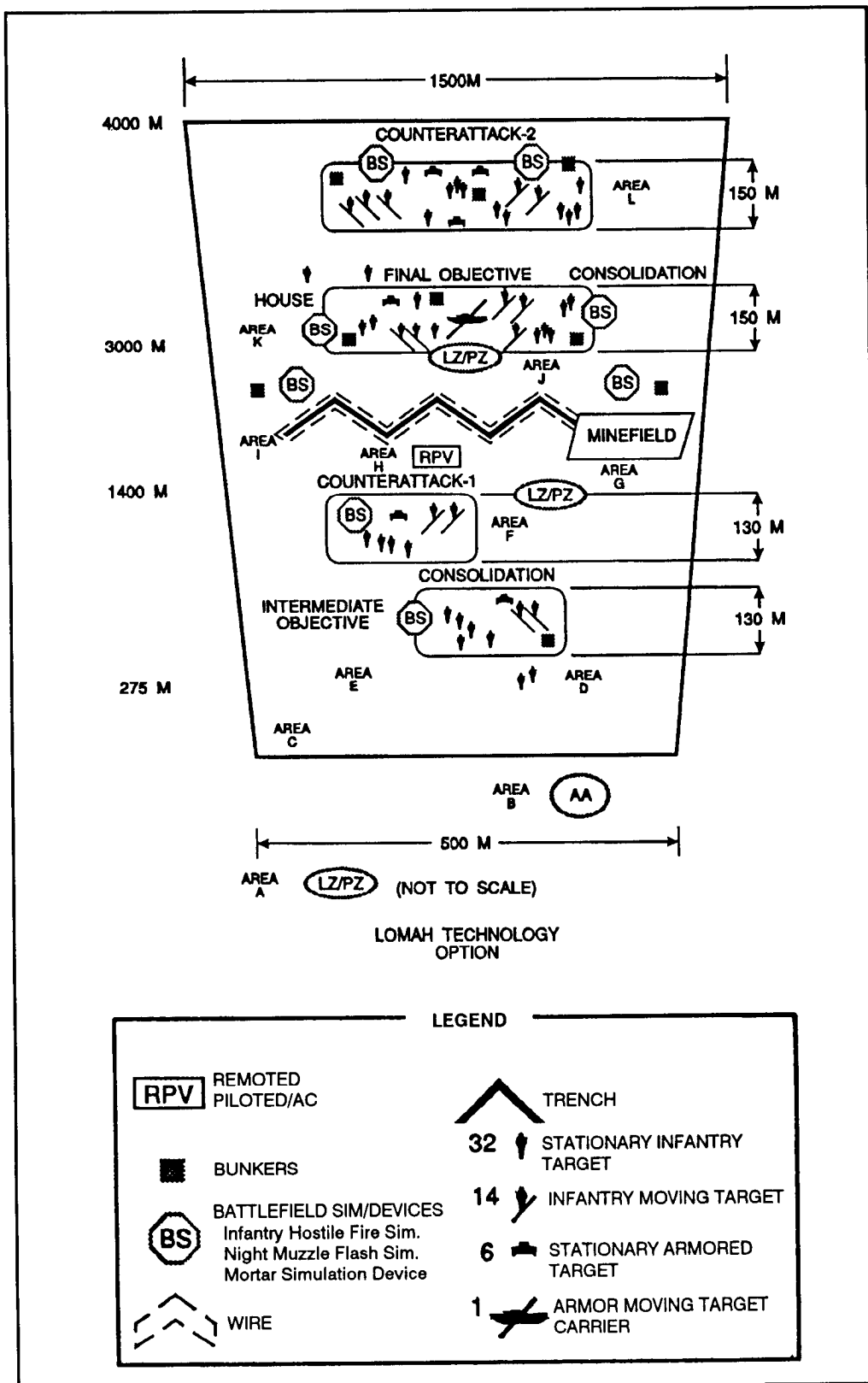

Figure K-2. Example of an Infantry platoon battle course (IPBC).

Use: The IPBC gives dismounted and mounted infantry platoons the opportunity to conduct fire and movement exercises in offense, defense, and retrograde operations.

Characteristics:

Baseline width is 500m; downrange width, 1500m; length of downrange area, 4000m. Downrange activity areas consist of—

- Area Controlment, 600m behind baseline.
- Area A: LZ/PZ, 400m behind baseline.
- Area B: Assembly Area (AA), 250m behind baseline.
- Area C: LD or baseline, 0m.
- Start point for downrange Area D: OP 250m downrange.
- Area E: Interim Objective, 1100m downrange.
- Area F: Counterattack area, 1500m downrange.

- Area G: LZ/PZ, 1900m downrange.
- Area H: Remoted pilotless vehicle (RPV) TASC RCMAT, 2200m downrange.
- Area I: Wire/trench/minefield obstacles downrange.
- Area J: LZ/PZ, 3100m downrange.
- Area K: Final objective, 3500 downrange.
- Area L: Counterattack area, 3850m downrange.

Targetry configuration - Targetry must be emplaced to present a target for both the base of fire element and the maneuver element throughout the entire range. Required targetry and training structures are listed in the table below.

Associated facilities - standard facilities.

References - ARTEP 7-8-Drill, ARTEP 7-8-MTP.

Objective	SAT	AMTC	SIT	IMT	IHFS*	MSD	Bunker [□]	House [□]	Trench
A	—	—	2	—	2	—	—	—	—
B	1	—	6	2	6	1	1	—	—
C	1	—	5	2	5	1	—	—	—
D	—	—	2	—	2	2	2	—	1
E	1	1	14	5	14	2	3	1	—
F	3	—	14	5	14	2	3	—	—
Total	6	1	43	14	43	8	9	1	1

*Optional.

□There are two SITS located in the assault/defend house, and one SIT associated with each machine gun bunker.

Figure K-2. Example of an infantry platoon battle couse (IPBC) (continued).

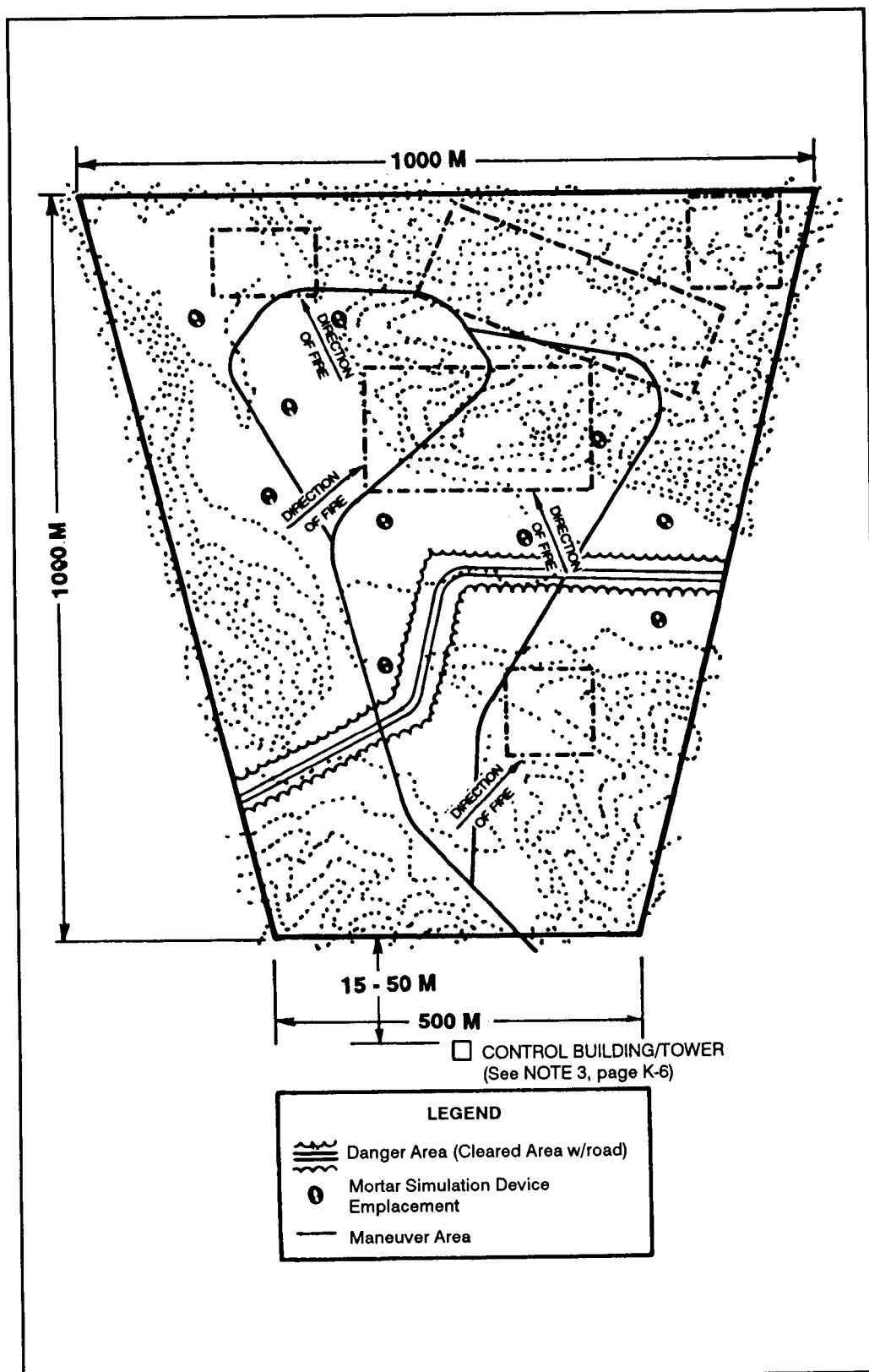

Figure K-3. Example of an infantry squad battle course (ISBC).

<p>NOTES:</p> <p>1. ISBC layout depicts target positions and training scenario specifically tailored for the topography shown. The location of target grouping A,B,C, and D must be sited in the areas that support training strategies based on site-specific conditions.</p> <p>2. Range boundaries are generic and represent maximum expected land use requirements. Actual range boundary configuration may vary depending on site-specific conditions.</p> <p>3. Site control building/tower 15-50 meters from the baseline in an area that will provide an unobstructed view to the baseline.</p>								
NO. OF TARGETS AND TRAINING STRUCTURES REQUIRED PER OBJECTIVE								
OBJ	SAT	AMTC	SIT	IMT	IHFS	MG Bunker	OB Bunker	Trench
A	0	0	4	0	4	0	0	0
B	2	0	6	2	8	2	0	2
C	2	1	0	0	0	0	1	0
D	1	0	5	2	5	1	0	0
E	1	0	5	2	5	1	0	0

Figure K-3. Example of an infantry squad battle course (ISBC) (continued).

K-2. TRAINING OBJECTIVES

Training objectives vary based on the size of the element to be trained, the unit’s experience, and the unit’s METL. The following example illustrates this point:

An infantry commander knows that his unit has little live-fire experience. He decides that he wants to conduct a platoon LFX in a maneuver box in six months. He first reinforces buddy team fire and movement on the installation’s fire-and-movement range. (Here his focus is on live-fire safety, individual movement techniques, and marksmanship). Next he trains his fire teams on reinforcing the concepts of fire control, fire discipline, and fire distribution through the use of fire commands on a KD range (rattle-battle drills). Then the commander trains his squads in fire control measures on an infantry squad battle course, integrating all previous training. Satisfied that his personnel are prepared in the rudiments of live fire, he conducts a leader’s CPX to rehearse command and control. He feels he is now ready to conduct a squad or platoon LFX in a maneuver box. He coordinates with range control for the terrain and local policies, and has TASC and DEH assist with targetry and site preparation. Next, the unit conducts a leader TEWT, a platoon walk-through, a platoon MILES rehearsal (force-on-force), and finally, the LFX (the first time soldiers actually see the targetry).

K-3. PLATOON MISSION

The unit decides which mission to train, based on its METL and past performance of various tasks. The location is determined by training

objectives; risk assessment; and range, equipment, and ammunition availability.

a. The movement to contact mission is presented on three different ranges: the MPRC, IPBC or ISBC, and the maneuver box. This shows the limiting factors of the MPRC and the IPBC or ISBC, and allows training objectives to be planned accordingly. Performing one of these before a free-form maneuver box allows more concentration on areas or tasks that need the most training. (For example: distribution of fires, fire discipline, and so on.)

b. No matter which kind of range is used, the following points should be remembered:

(1) During the exercise, fire directed at nontarget obstacles such as trees, rocks, dud or discarded ammunition, and the tracks or wheels of moving targets, should be prevented.

(2) When assaulting targets, personnel should cease fire within at least 20 meters of the target (depending on the weapon system used). Under no circumstances should fire be directed inside target pits (this could damage equipment).

(3) OCs must constantly stress the need to keep the weapon's muzzle directed away from friendly troops and the weapon on safe when not firing.

(4) Positive communications must be maintained.

(5) All unused ammunition should be turned in at the conclusion of the exercise to allow for an evaluation of the number of rounds expended compared to the number of hits obtained. (Units that dump ammunition penalize themselves by raising the number of rounds needed to hit each target.)

(6) An AAR should be conducted at the end of the exercise at the squad level, then at the platoon level. If multiple-phased operations are conducted, the unit may want to conduct an AAR after each phase.

c. Developing realistic scenarios helps get the most out of an LFX. Scenarios must be flexible enough to allow the commander and other leaders to decide how to use the terrain. They must also be extensive enough to facilitate training and evaluation of unit tasks executed IAW the commander's concept for the operation, which is formulated through a METT-T assessment. Scenarios must be varied enough to allow leaders to engage the proper targets with the right weapons at the appropriate times.

K-4. MULTIPURPOSE RANGE COMPLEX-LIGHT

The following example of platoon live-fire situational training exercise scenarios contain collective tasks and drills identified in appropriate MTPs. This is only one example of how to execute a mission. This particular scenario is divided into three phases. Each phase contains tasks

or drills that are achievable on the MPRC, and like all examples on all range types, concludes with an AAR. Some or all of the tasks listed may be included in each phase depending on the unit's training objectives. Time required to complete each phase depends on the number of tasks included and could be in excess of 12 hours if all tasks listed in the three phases are conducted. In addition, alternative plans could include running platoons consecutively through a single phase or running different platoons through each succeeding phase. Whatever approach is selected, the scenarios are based on only one platoon engaged in an LFX at one time on the MPRC. Remaining platoons may run exercises using MILES. Only those tasks identified as achievable on the MPRC should be trained here.

a. **Range and Targetry.** (See TC 25-8 for an example of an MPRC.)

(1) Targetry consists of nine moving vehicle targets, 37 stationary vehicle targets, 153 stationary E-type pop-up personnel targets, and 46 moving E-Type personnel targets.

(2) Targets are fully automated and self-scoring. Hostile fire simulators, thermal targets, night illumination devices, and visual flash simulators are all used on this range.

(3) Instruction and briefing classrooms, an administrative area, an ammunition breakdown area, and vehicle holding and maintenance areas are available.

(4) This type of range is approximately 4,500 meters long and 1,000 wide. (This measurement does not include an assembly area.)

b. **Scenario.**

(1) **General situation.** The battalion has seized key terrain within its area of operations. Contact with enemy elements has been broken. Intelligence reports indicate the enemy has withdrawn, is reinforcing, and has the capability to counterattack in regimental strength within the next 12 hours.

(2) **Special situation.** The company is in an assembly area when ordered to conduct a movement to contact within zone to PL ____, seize objective ____, and be prepared to continue the advance. The company commander's FRAGO specifies the axis of advance. It also specifies that an enemy squad or larger formations will not be bypassed unless ordered and that movement will orient on objective ____.

(3) **Phase I.** The platoon, as part of the company movement to contact, comes under direct fire from an opposing force (OPFOR) squad. The platoon executes its battle drill, develops the situation, and conducts a hasty attack. Following consolidation and reorganization on the objective (if needed), weapons are cleared and checked, and an AAR is conducted. The platoon may retrain the phase as necessary to attain the overall training objective or be succeeded by another platoon.

(4) **Phase II.** The platoon continues the movement to contact mission and executes optional cross danger area, breach obstacles, or clear woodland battle drills. A squad comes under ambush from an OPFOR squad and is ordered to break contact. The platoon reorganizes to continue the mission. Weapons are cleared and checked, and an AAR is conducted. The platoon may retrain the phase as necessary to attain the overall training objective or be succeeded by another platoon.

(5) **Phase III.** The platoon continues the movement to contact mission and comes under direct fire from an OPFOR squad near objective____. The platoon executes battle drill, develops the situation, and assaults the objective. The platoon consolidates and reorganizes and establishes a defense. Weapons are cleared and checked, and an AAR is conducted. The platoon may retrain the phase as necessary to attain the overall training objective.

c. **Weapon Accommodation.** The MPRC-L has pre-imposed weapon caliber restrictions. Because it is a fixed site, obtaining waivers or physically changing the range is difficult.

K-5. INFANTRY PLATOON BATTLE COURSE

The IPBC provides a range where a dismounted infantry platoon can conduct mission-oriented training exercises IAW ARTEP 7-8-MTP. The IPBC can accommodate the following training exercises:

- Ambush.
- Movement to contact.
- Attack.
- Raid.
- Retrograde.
- Defend.
- Reconnaissance and security.

The IPBC is not designed to accommodate aerial gunnery support activities. Each IPBC is tailored to the requirements set by the installation's training requirements and the specific site terrain features. The strategies for final range layout will be based on the following criteria:

- Training directives, priorities, and guidance established by the installation's chain of command.
- Platoon battle tasks.
- Platoon mission-essential task list.
- Training priorities of the platoon.
- Training resources and availability.
- Terrain availability.

This type of range is approximately 4,000 meters long and 1,500 wide. (This measurement does not include an assembly area.)

a. **Range and Targetry** (Figure K-2).

(1) **Targetry.**

(a) Objective A consists of two stationary infantry targets (SIT) simulating a enemy outpost position. Objective A will be sited approximately 250 meters down range on a ridge line or other strategic area that can be engaged from a frontal suppressing engagement and a lateral (flanking) defeating engagement.

(b) Objective B consists of two groupings. The first group should contain four SITs, one infantry moving target (IMT), and one machine gun bunker. The second group should contain two SITs, one IMT, and one stationary armor target (SAT). One mortar simulation device (MSD) should also be included within objective B. Objective B should be located approximately 1,100 meters from the baseline.

(c) Objective C consists of five SITs, two IMTs, one SAT, and one MSD. Objective C should be located approximately 1,500 from the baseline.

(d) Objective D consists of a trench with a machine gun bunker, one SIT, and an MSD at each end. Objective D also contains a minefield and or an impassable contaminated area that will channel troops toward the trench. Objective D should be located approximately 2,600 meters from the baseline.

(e) Objective E consists of three target groupings. The first group contains seven SITs (two located in the two-story house), two IMTs, one SAT, one machine gun bunker, and one MSD. The second group contains one machine gun bunker and one SIT. The third group contains six SITs, three IMTs, one armor moving target carrier (AMTC), one machine gun bunker, and one MSD. Objective E should be located approximately 3,500 meters from the baseline.

(f) Objective F consists of three target groupings. The first group contains three SITs, three IMTs, one SAT, one machine gun bunker, and one MSD. The second group contains six SITs, one SAT, and one machine gun bunker. The third group contains five SITs, two IMTs, one SAT, one machine gun bunker, and one MSD. Objective F should be located approximately 3,850 meters from the baseline.

(2) **Bunkers.**

(a) Bunkers will probably be of all wood construction and include a mechanism to simulate machine gun fire. They should have at least three walls and should be strategically located using natural cover.

(b) Each machine gun bunker should be accompanied by one SIT, one night muzzle flash simulator (NMFS), and one infantry hostile fire simulator (IHFS). The SIT, NMFS, and IHFS should be positioned to

draw attention to the bunker. To accommodate the standard design, the SIT, NMFS, and IHFS should be located outside the bunker. If the bunker will be used to practice clearing techniques, the SIT, NMFS, and IHFS MUST be positioned outside the bunker. If no clearing of the bunker will take place, the SIT and NMFS maybe mounted inside the bunker.

(3) **Trench layout.** The location and layout of trench lines are IAW enemy doctrine. They are squad size and generally linear. Individual fighting positions are spaced approximately 5 meters apart. The total length should be approximately 50 to 60 meters. According to enemy strategies, antitank and antipersonnel obstacles are normally erected in front of the trench line.

(4) **Assault-defend house.** The assault-defend house is a two-story structure with targets in the windows of the lower level of the assault side. The first floor of the assault side is not intended to be accessed during training exercises. The door will be secured with a hasp and padlock. (See FM 90-1 for MOUT operations.)

(5) **Landing zone/pickup zone (LZ/PZ).** Troop transportation down range requires that certain areas of the range be designated for helicopter accessibility. Each IPBC will have a different LZ/PZ location.

b. Scenario.

(1) **General situation.** The battalion has seized key terrain within its area of operations. Contact with enemy elements has been broken. Intelligence reports indicate the enemy has withdrawn, is reinforcing, and has the capability to counterattack in regimental strength within the next 12 hours.

(2) **Special situation.** The company is in an assembly area when ordered to conduct a movement to contact within zone to PL ___, seize objective ___, and be prepared to continue the advance. The company commander's FRAGO specifies the axis of advance. It also specifies that an enemy squad or larger formations will not be bypassed unless ordered and that movement will orient on objective ___.

(3) **Phase I.** The platoon, as part of the company movement to contact, comes under direct fire from an opposing force (OPFOR) squad. The platoon executes its battle drill, develops the situation, and conducts a hasty attack. Following consolidation and reorganization on the objective (if needed), weapons are cleared and checked, and an AAR is conducted. The platoon may retrain the phase an necessary to attain the overall training objective or be succeeded by another platoon.

(4) **Phase II.** The platoon continues the movement to contact mission and executes optional cross danger area, breach obstacles, or clear woodline battle drills. It then comes under direct fire from an OPFOR squad near objective ___. The platoon executes battle drill, develops the situation, and assaults the objective. The platoon consolidates and

reorganizes and establishes a defense. Weapons are cleared and checked, and an AAR is conducted. The platoon may retrain the phase as necessary to attain the overall training objective.

c. Weapon Accommodation.

(1) The IPBC range has pre-imposed weapon caliber restrictions. Because it is a fixed site, obtaining waivers or physically changing the range is difficult.

(2) For dismounted operations, the IPBC accommodates all small arms up to the M60 machine gun (7.62-mm). The IPBC can also handle mounted operations to include the 25-mm cannon, M47 Dragon, and .50 caliber machine gun.

K-6. MANEUVER BOX.

Movement to contact simulates a third-world infantry force conducting a movement to contact to engage a friendly force.

a. Range and Targetry.

(1) The lane has targets constructed of plywood or pressboard with metal spring joints, clothed in OPFOR uniforms. Targets will be activated by an OC using an electronic transmitter. When a target is hit, a mechanism is activated causing the target to drop to the ground.

(2) Pneumatic firing devices with MILES transmitters attached to a vehicle windshield motor will create a fan of return fire. This "fire" will be supplemented by the controllers when soldiers commit an unsafe or unrealistic act. All targetry equipment will be hardened as much as possible to protect it from weapon systems employed in the LFX.

(3) For a movement to contact, this type of range is approximately 3,000 to 5,000 meters long and 800 meters wide. (This measurement does not include an assembly area or the SDZs which merge into the impact area.) The size of the maneuver box can be adapted to the mission and terrain. (An ambush or attack mission might require a box 2,000 meters by 1,000 meters.)

b. Scenario.

(1) **General situation.** The battalion has seized key terrain within its area of operations. Contact with enemy elements has been broken. Intelligence reports indicate the enemy has withdrawn, is reinforcing, and has the capability to counterattack in regimental strength within the next 12 hours.

(2) **Special situation.** The company is in an assembly area when ordered to conduct a passage of lines, followed by a movement to contact within zone to PL___, seize objective ___, and be prepared to continue the advance. The company commander's FRAGO specifies the axis of advance. It also specifies that an enemy squad or larger formations will not

be bypassed unless ordered and that movement will orient on objective ____.

(3) **Phase I.** The platoon, as part of the company movement to contact, comes under direct fire from an opposing force (OPFOR) squad. The platoon executes its battle drill, develops the situation, and conducts a hasty attack. Following consolidation and reorganization on the objective (if needed), the platoon continues the movement to contact.

(4) **Phase II.** The platoon continues the mission and executes optional cross danger area, breach obstacles, or clear woodland battle drills. It then comes under direct fire from an OPFOR squad near objective _____. The platoon executes battle drill, develops the situation, and assaults the objective. The platoon consolidates and reorganizes and continues the mission. Weapons are cleared and checked, and an AAR is conducted. (The platoon may continue the mission as long as necessary to attain the overall training objective.)

c. Weapon Accommodation.

(1) Weapons systems used will vary by installation, depending on terrain available. The JRTC uses up to 40-mm M203 practice rounds and AT4s on its movement to contact range. (It also uses live Claymores in its ambush scenario, and live grenades, mortars, artillery, and bangalore torpedoes in its deliberate attack scenario.)

(2) The SDZ will be based on the largest caliber ballistic weapon/munitions to be used. The SDZ is designed to provide the platoon with the maximum flexibility in the selection of tactically sound movement techniques throughout the area. Specifically, the SDZ needs to be plotted from the most probable axis of march that the platoon leaders might select. This axis of march can be influenced through operations orders defining boundaries, restrictive fire areas, and so on, and controlling which target array will be activated. Using the extreme engagement limits, the maximum distance of fire is plotted to the left, right, and forward of the participating unit's line of fire. The possibility of an injury caused by friendly fire is increased on this range. Care must be taken to ensure that personnel follow the safety precautions presented in the safety briefing.

GLOSSARY

AAR	after-action review
AMTC	armor moving target carrier
AR	Army Regulation
ARTEP	Army Training and Evaluation Program
ASP	ammunition supply point
ATGM	antitank guided missile
ATWESS	antitank weapon effect signature simulator
BOS	battlefield operating system
CAS	close air support
CTC	combat training center
DZ	drop zone
EA	engagement area
EOD	explosive ordnance detachment
FCX	fire coordination exercise
FIST	fire support team
FO	forward observer
FRAGO	fragmentary order
FSO	fire support officer
FTX	field training exercise
GP	general purpose; group
IAW	in accordance with
IET	initial entry training
IHFS	infantry hostile fire simulator
IMT	individual movement techniques, infantry moving target
IN	infantry
JRTC	Joint Readiness Training Center
KD	known-distance
LD	line of departure
LFX	live-fire exercise
LZ	landing zone
MACOM	major Army command
MACS	multipurpose arcade combat simulator

MEDEVAC	medical evacuation
METL	mission-essential task list
METT-T	mission, enemy, terrain, troops and time available
MILES	multiple-integrated laser engagement system
MOGAS	motor gasoline
MOUT	military operations on urbanized terrain
MPRC	multipurpose range complex
MPRC-L	multipurpose range complex-light
MRE	meal, ready-to-eat
MSD	mortar simulation device
MTC	movement to contact; moving target carrier
MTP	mission training plan
NBC	nuclear, biological, and chemical
NCO	noncommissioned officer
NMFS	night muzzle flash simulation
NVD	night vision device
OC	observer-controller
OIC	officer in charge
OP	observation post
OPFOR	opposing force
OPORD	operations order
PL	phase line
PLT	platoon
PSG	platoon sergeant
PZ	pickup zone
RCMAT	radio-controlled miniature aerial target
RETS	remoted target system
RFA	restrictive fire area
RFL	restrictive fire line
SAT	stationary armor target
SDZ	surface danger zone
SIT	stationary infantry target
SOP	standing operations order
SPALS	simulator, projectile airburst liquid
SQD	squad
STX	situational training exercise
SWA	Southwest Asia
T&EO	training and evaluation outline
TBA	to be announced
TBD	to be determined

TEWT	tactical exercise without troops
THM-TG	target holding mechanism tank gunnery
TLP	troop-leading procedure
TM	team
TNT	trinitrotoluene
TOT	time of transmission; time on target (artillery support); or time over target (air support)
TOW	tube-launched, optically tracked, wire-guided
TP-T	training practice tracer
TRP	target reference point
TSC	training support center
US	United States
VT	variable time
XO	executive officer

REFERENCES

DOCUMENTS NEEDED

These documents must be available to the intended users of this publication.

- AR 385-63 Policies and Procedures for Firing Ammunition for Training, Target Practice and Combat. 15 October 1983.
- DA Pam 350-38 Training Standards in Weapon Training. 1990.
- FM 7-7 The Mechanized Infantry Platoon and Squad. 15 March 1985.
- FM 7-8 The Infantry Platoon and Squad (Infantry, Airborne, Air Assault, Ranger). 2 April 1992.
- FM 23-9 M16A1 Rifle and M16A2 Rifle Marksmanship. 03 July 1989.
- FM 25-4 How to Conduct Training Exercises. 10 September 1984.
- FM 25-7 Training Ranges. 16 September 1985.
- FM 90-10 Military Operations on Urbanized Terrain. 15 August 1979.
- FM 90-10-1 An Infantrymen's Guide to Urban Combat. 30 September 1982.

READINGS RECOMMENDED

These readings contain relevant supplemental information.

- FM 7-70 Light Infantry Platoon and Squad. September 1986.
- FM 20-32 Mine/Countermine Operations. December 1985.
- FM 21-60 Visual Signals. September 1987.
- FM 21-75 Combat Skills of the Soldier. 3 August 1984.
- FM 22-102 Soldier Team Development. March 1987.
- FM 23-1 Bradley Fighting Vehicle Gunnery. March 1991.
- FM 23-12 Technique of the Fire of the Rifle Squad and Tactical Application. October 1967.

FM 23-14	Squad Automatic Weapon (SAW) M249. December 1985.
FM 23-23 (w/C2)	Antipersonnel Mine M18A1 and MIS (Claymore). January 1966.
FM 23-24	Dragon Medium Antitank/Assault Weapon System M47. April 1990.
FM 23-25	Launcher and Cartridge 84-mm, M136 (AT4), HEAT. June 1988.
FM 23-27	MK 19 40-mm Grenade Machine Gun MOD 3. December 1988.
FM 23-30	Grenades and Pyrotechnic Signals. December 1988.
FM 23-31 (w/CI)	40-mm Grenade Launchers M203 M79. May 1972.
FM 23-33 (w/CI)	66-mm HEAT Rocket M72A1 and M72A2 (LAW). April 1979.
FM 23-34	TOW Weapon System. September 1987.
FM 23-65	Browning Machine Gun Caliber .50 HB, M2. May 1972.
FM 23-67 (w/CI)	Machine Gun 7.62-mm, M60. February 1984.
FM 23-85	60-mm Mortar, M19. February 1967.
FM 25-100	Training the Force. November 1988.
FM 25-101	Battle Focused Training. September 1990.
FM 71-1	Tank and Mechanized Infantry Company Team. November 1988.
FM 101-5-1	Operational Terms and Symbols. October 1985.
TC 7-1	The Rifle Squads (Mechanized and Light Infantry). 31 October 1974.

INDEX

- after-action reviews, 3-2, 4-6, 5-9, 6-6, H-4
- ammunition requirements, F-1
 - buddy team, 3-6
 - fire team, 4-7
 - platoon, 6-9
 - squad, 5-11
- buddy team, 3-1
 - collective tasks, 3-2
 - defense, 3-3, 3-4 (illus)
 - objectives, 3-1
 - offense, 3-5
- casualties, C-1
- chemical contamination, C-3
- command and control, 2-9
- communication, 2-9, 6-2, D-2
- concept, 2-5
 - crawl, walk, run, 2-5
- duds, A-13
- explosives, C-3
- fighting positions, 2-1
 - kneeling, 2-2, 2-3 (illus), 2-4 (illus)
 - prone, 2-1, 2-4 (illus)
 - standing, 2-2 (illus), 2-3
 - supported, 2-1
- fire control, 2-9, 4-3, 5-2, I-1
 - engagement areas, I-2
 - fire patterns, I-4 (illus)
 - phase lines, I-3
 - sector of fire, I-1
 - target reference points, I-2
- fire team, 4-1
 - fire control, 4-3
 - focus, 4-2
 - objectives, 4-2
- land mines, C-4 (illus)
- logistic support, 3-6, 4-6, 5-11, 6-8
- maneuver box, 1-3
- marksmanship, 1-2, 2-1, E-2
 - collective, 1-3, 1-5, 2-1
 - mobile, 1-3, 1-5, 2-5
 - static, 1-3, 1-5, 2-5
- medical evacuation, A-13
- movement techniques, E-1
- night exercises, D-1
 - communications, D-2
 - devices, D-2
 - illumination, D-3
 - markers, D-1
 - rehearsals, D-1
- objectives, 2-5
- observer-controllers, 5-8, 6-6, H-1
 - functions, H-1
- obstacles, 2-7
- platoon, 6-1
 - fire control, 6-3
 - mission, 6-6
 - objectives, 6-1
 - planning, 6-3 (illus)
- safety, 1-1, 2-7, 2-10, A-1, B-1
 - briefing, A-10 (illus)
 - checklists, A-7 (illus)
 - recommendations, A-4
 - risk assessment, A-1, A-2 (illus), A-3
- site development, B-2
- squad, 5-1
 - fire control, 5-2
 - mission, 5-9
 - objectives, 5-1
 - planning, 5-3, 5-4 (illus)
- subcaliber devices, C-13
- suppression, 2-8
 - direct fire, E-2
- targetry, C-6 (illus), C-7 (illus), C-8 (illus), C-9 (illus), C-10, (illus)
- training, 1-1, 1-7
 - aids, 1-8 (illus)
 - buddy-team, 3-1
 - building blocks, 1-7, 1-8
 - fire-team, 4-1
 - platoon, 6-1
 - squad, 5-1
 - stages, 1-5, 1-6
 - strategy, 1-1
 - cycle sustainment, 1-5
 - development, 1-3

TC 7-9
30 SEPTEMBER 1993

By Order of the Secretary of the Army:

Official:

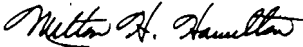
MILTON H. HAMILTON
*Administrative Assistant to the
Secretary of the Army*
04924

GORDON R. SULLIVAN
*General, United States Army
Chief of Staff*

DISTRIBUTION:

Active Army, USAR, and ARNG: To be distributed in accordance with DA Form 12-11E, requirements for TC 7-9, Infantry Live-Fire Training (Qty rqr block no. 5146).